

PowerTouch 814

Manual C814.N2
Drawing D814.N2 Rev 0 January 23, 2002
Rev A 04.14.03 pgs 1, 4, 5, 6, 7, 11 only

❖ By TouchTronics, Inc.

**Economical
and
Compact**



814 PowerTouch Remote Control Receiver
With Two Key Chain Transmitters and
Shown With Optional Oval Transmitter

**Please read entire instruction manual *prior* to starting the
PowerTouch Remote Control System Installation.**

Special Features and Applications

Flexibility

Installer can select polarity of voltage outputs on two different channels.

Compact

Receiver is small and easy to install.

Optional Transmitters

Large, oval transmitters with large buttons can be ordered.

Extra Channels

Two extra channels are available at no extra cost.

Range

Typical antenna range is 60-feet.

Contents

Special Features and Applications	Page 1
Contents, Specifications, Installation Tools, Technical Support	Page 2
Component Parts List	Page 3
Operation: Remote Control	Page 3
Installation: Planning	Page 4
Installation: Receiver Power & Ground	Page 4
Installation: Electrical	Page 5
Installation: Application Schematics	Page 6
Installation: Motors Using Relays, Safety Disable Switch	Page 7
Trouble Shooting Guide	Page 8, 9, 10
Limited One (1) Year Warranty	Page 11
Blank Page (Installation Notes or Diagrams)	Page 12

Specifications

814 Receiver:	FCC Approved
RF System	6561 Digital Codes
Voltage	12 Volt DC (available in 24 Volt DC)
Output	300mA
Frequency	303 MHz
Range	60 Feet (typical - using standard 36" grey, wire style, antenna)
Note:	Range may be extended with an externally mounted antenna
814 Transmitter:	FCC Approved
RF System	6561 Digital Codes
Battery	12 Volt DC
Cycles	32,400 One Second Pulses
Frequency	303 MHz
Note:	Key chain style transmitters are water resistant, NOT water proof Oval style transmitters are water and dust resistant
Physical:	
Receiver:	3" x 1" x 2" (width, height, depth)
Transmitter:	1 ½" x 2" (width, length) key chain style 2" x 4 ½" (width, length) oval(hand held) style

Installation Tools

Voltmeter, analog or digital
Phillips Screw Driver
Adjustable Wrench
Screw Driver
Wire Cutter
Wire Stripper
To Clean Grounding Pad: Scraper, Sand Paper, Alcohol Based Cleaner

Technical Support

Visit the factory website to download a copy of these instructions, e-mail technical questions and see other TouchTronics, Inc. products.

Phone / Fax Numbers

Indiana Local 1-574-294-2570
Toll Free 1-800-294-2570
Fax 1-574-293-1611





Web Site

www.touchtronics.com

E-Mail

Touchtronics@touchtronics.com or
techsupport@touchtronics.com or
'Contact Request' link on the web page

Component Parts List

- | | | | | |
|----------|-------|----------------|---|---|
| 1) | 1 pc | 814r | RF Receiver, 4 Channel
w/36" antenna wire |  |
| 2) | 1 set | 814h | Harness - 8 wire, 9" |  |
| 3) | 2 pcs | 814T3 | Transmitter,
3 button key chain style |  |
| Optional | | 814T4XS | Transmitter,
4 button oval (hand held) style |  |

Operation: Remote Control

Transmitters:

- | | | |
|----|---------------------------------------|---|
| 1) | Press and release button
Or | Signal is sent to receiver - 1 second pulse |
| 2) | Press and hold button | Signal is sent to receiver as long as button is held. Signal will stop when button is released. |
| 3) | Red Status LED | A) LED On red indicates signal is being sent
B) LED On bright indicates battery voltage is ok. |

Transmitter Operation		Receiver Operation			
Button	Channel	Function	Output	Signal Output	Signal Type
A	1	Motor or Lamp	300mA Max	+12v or Ground(-)	Momentary
B	2	Motor or Lamp	300mA Max	+12v or Ground(-)	Momentary
A & B Pressed @ same time	3	Motor or Lamp	300mA Max	Ground (-)	Momentary
Back Button	4	Motor or Lamp	300mA Max	Ground (-)	Momentary

Installation: Planning

1) Receiver Output Voltages

- A) The receiver has four output voltage (channels) which will operate four separate circuits. The output voltage is 12 volts direct current (vdc). The maximum drive current for each of the four output channels is **300mA (maximum)**. The four outputs can (drive) turn On small bulbs or relay coils.
- B) Check the power requirement for the bulb before connecting to the receiver. 12vdc at 0.1amp (maximum) or 1 watt (maximum)
- C) Check the power requirement for the relay before connecting to the receiver. The relay coil should be rated for the current requirements. The maximum allowable coil current is 300mA.

2) Determine where the receiver and antenna will be located.

Typically the RF receiver is located under the dash or behind a wall panel in the back. If the receiver is to be mounted outside the cab area then you must protect the receiver. The receiver is NOT waterproof or moisture resistant*.

DO NOT mount the receiver and antenna:

- A) Within 6 feet of a motor
- B) Near large bundles of wires
- C) Near other antennas or RF devices
- D) The antenna should not be touching any metal as this grounds the RF (radio frequency) signal

*TouchTronics offers weather resistant housings for many different types of applications. Call the factory @ 1-800-294-2570 for information on your particular application needs.

Installation: Receiver Power & Ground

WARNING!

Use **ONLY** a volt meter to check voltage during installation and testing.

**Using a test light WILL damage the outputs!*



***Maximum output current 300mA.
Over current will damage outputs.**

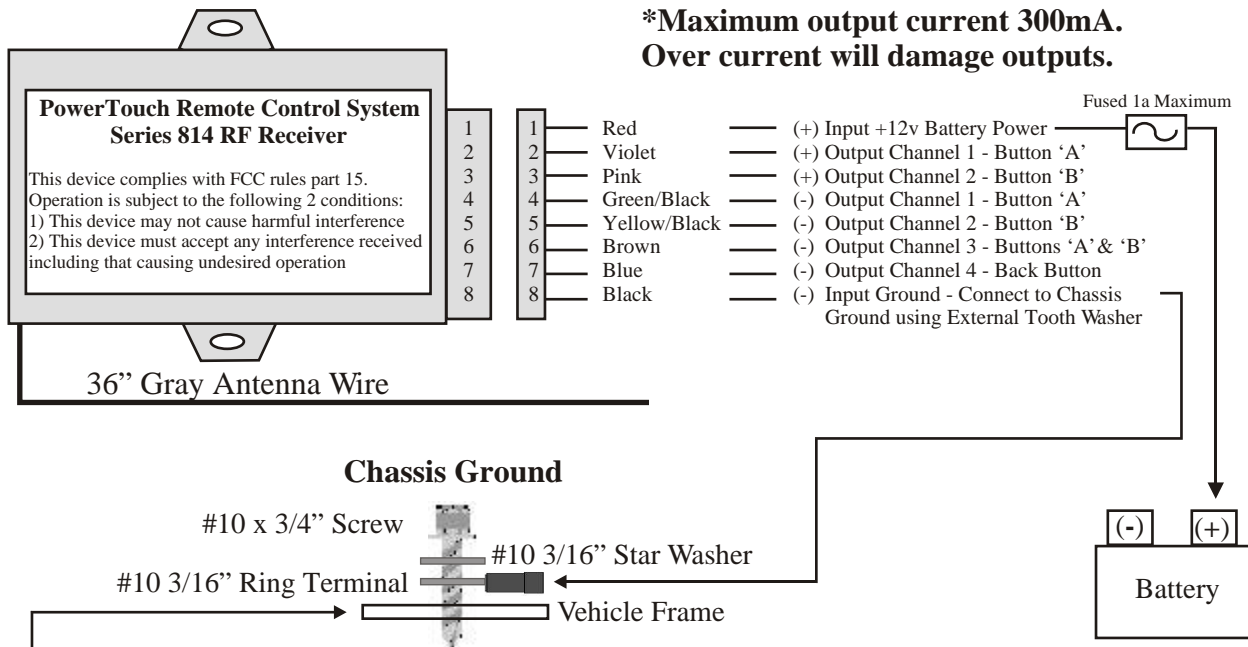

Scrape paint and clean area before installing ground screw.

A loose chassis ground connection WILL cause intermittent operation!

Installation: Electrical

1) Install Power

Connect the Red wire to a constant +12v battery power source. Note: For best performance, run a clean +12v (300mA) directly from the battery or a fuse that is NOT supplying any power to motors, lights or any other type of high current device.

2) Install Ground

Connect the Black wire to chassis ground

A) Scrape all paint and grease away from the body frame.

A loose chassis ground connection WILL cause intermittent operation of receiver.

B) Clean the area using an alcohol based cleaner to remove paint chips and grease.

C) Crimp a #10, 3/16" ring terminal onto the black ground wire.

D) Insert the ring terminal and a #10, 3/16" star washer over a 10x3/4" hex head, self-tapping ground screw.

E) Tighten ground screw securely into clean frame area.

3) Install Outputs - Maximum output is 300mA

****Unit will be damaged if more than 300mA is drawn from any one circuit.**

A) Connect *only One* Channel output wire at a time to a relay or function which uses 300mA or less. (On channels 1 and 2; choose *either* the negative or the positive wires, NOT both)

B) Solder connections and protect with shrink tube or use an 18g insulated butt terminal.

Channel	Output	Wire Color	Max Output	Pin Position
Channel 1	(+) positive	Violet	300mA	2
	(-) negative	Green/Black	300mA	4
Channel 2	(+) positive	Pink	300mA	3
	(-) negative	Yellow/Black	300mA	5
Channel 3	(-) negative	Brown	300mA	6
Channel 4	(-) negative	Blue	300mA	7

See Diagram on Page 4

WARNING!

If the output wires are installed to the wrong polarity, the output will be damaged. For example: if the channel 2 pink (+12) output wire is connected to a ground, a 'dead short' will occur when the button is pressed. The output will test 'dead' and the trace may be burned or test 'high (On)' at all times.

4) Wiring Inspection

A) Check all wiring connections visually

B) Check the polarity of all wires

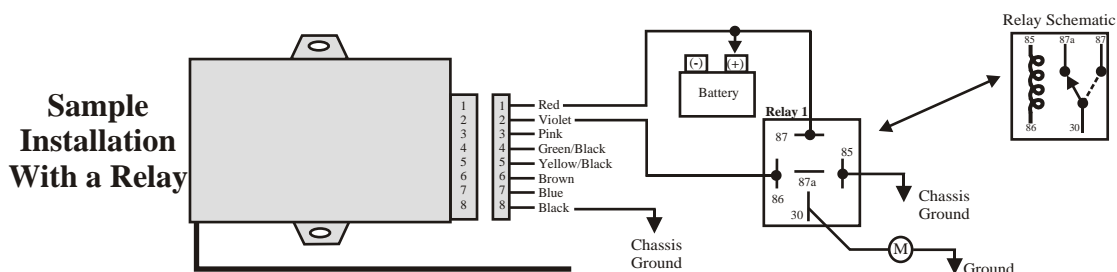

Installation: Suggested Application Schematics

The following schematics are for reference only. The installer must verify that the circuit is properly wired with the correct gauge of wire, and properly fused with the correct fuse size and type for the circuit.

Vehicle window switches and door lock switches can be designed as a positive pulse, a negative pulse or a reversal rest @ ground circuit.

To determine which type is used in your vehicle, take a voltmeter and probe one of the output wires a the switch. Check the polarity with the switch pressed and without the switch pressed. Compare results with the chart below.

Window or Door Lock Switch	Switch NOT Pressed	Switch Pressed	Typical # of Wires
Positive Pulse	No Voltage / Floats	+12 Volts	3 Wires
Negative Pulse	No Voltage / Floats	Ground	3 Wires
Reversal Rest@Ground	Ground	+12 Volts	5 Wires

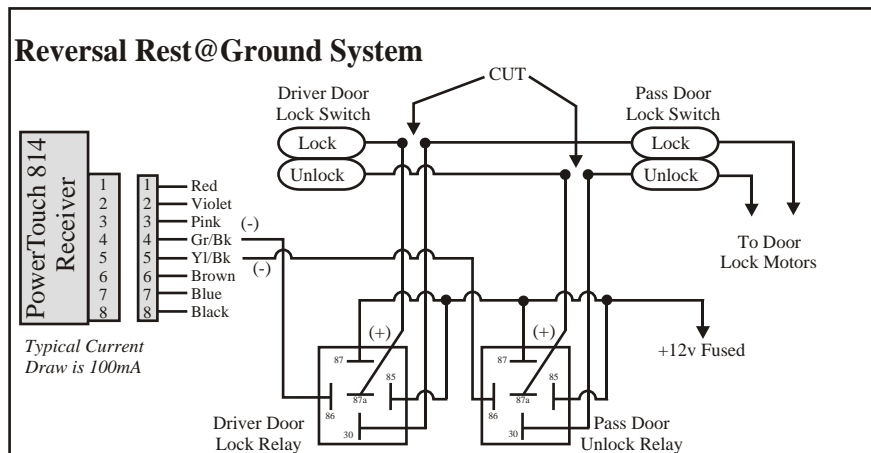
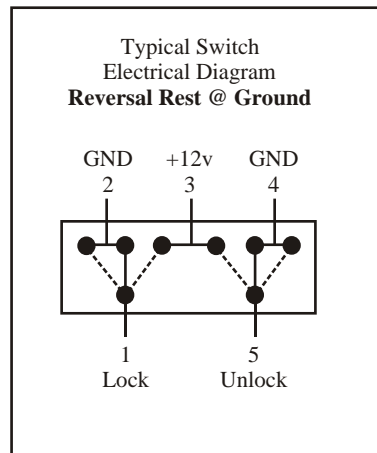
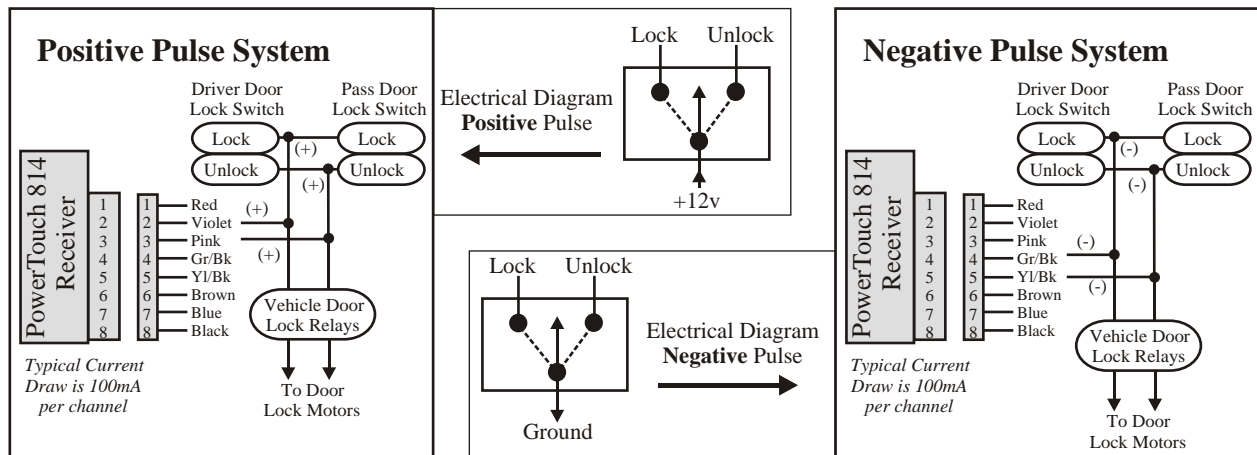

****Please Note:**

Due to continually changing wire colors through-out the automotive industry, TouchTronics can NOT provide accurate wire color information on a consistent basis. Therefore, if the wire colors needed for installation are not known, please contact a local dealer and they should be able to provide any necessary information.

Installation: Motors Using Relays, Safety Disable Switch

WARNING! *If using any type of motor, such as a window motor, a ramp motor, a door motor, or a winch motor - add a Disable switch to prevent the door or window circuit from operating when vehicle is in motion.*

A disable switch should be installed in many applications to deny operation of the motor when a vehicle is in motion. However, due to changes in automotive electrical design and the addition of computer controlled circuits, it is no longer advisable or safe to tap into or cut wires to disable automotive factory circuits. To overcome this problem, you must install an electro-mechanical switch which will determine gear position, thus safely disabling the circuit while the vehicle is in motion. Below are three options for installing a Safety Disable Switch.

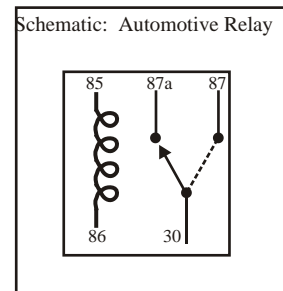
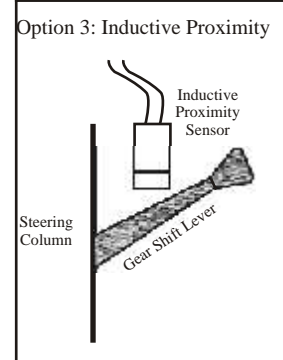
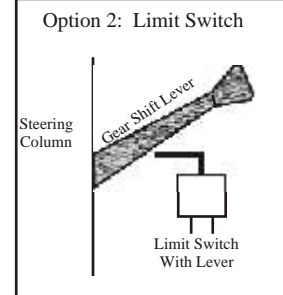
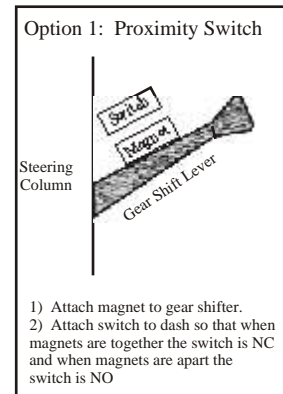
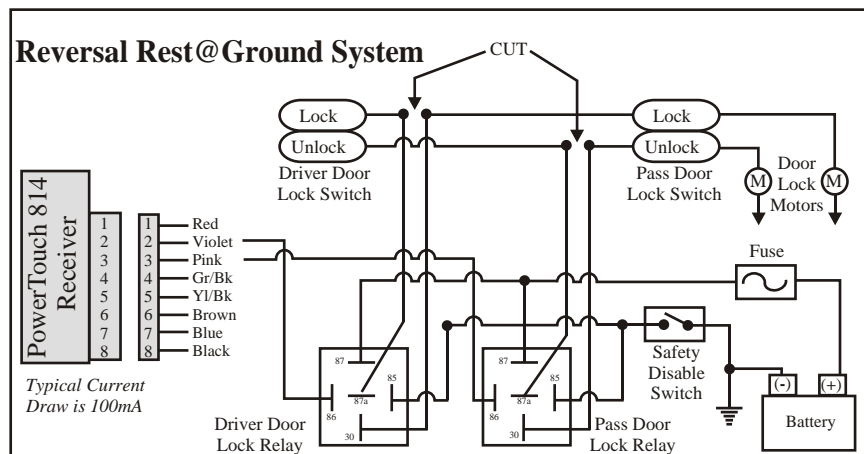
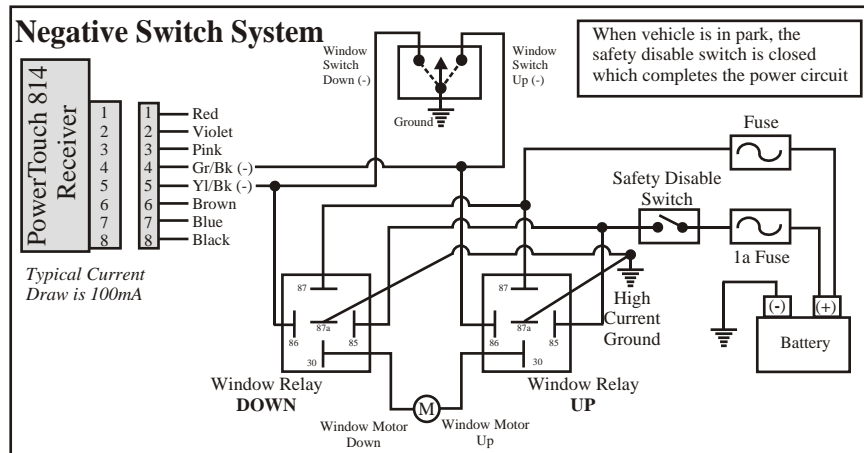
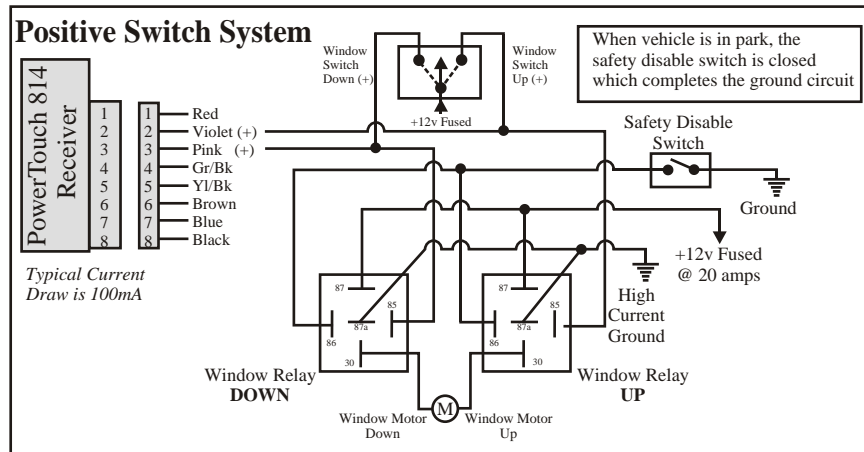

Trouble Shooting Guide - 814 Series Remote Control



**Use a digital or analog voltmeter to check power and voltage!
Do NOT use a test light**

Symptom	Possible Cause	Corrective Action
<p>1.0 No output from one or more channels on remote control receiver</p>	<p>1.1 No signal from transmitter</p> <p>1.2 One or both of the outputs have failed.</p> <p>1.3 Receiver outputs ok, but relays or equipment do not operate.</p>	<p>1.1 Verify that transmitter is sending a signal and that transmitter is coded correctly. See symptom 3.00</p> <p>1.2a Press each transmitter button in sequence. While pressing button, <i>use only a voltmeter probe</i> to check each corresponding output (Green/black = button 'A') (Yellow/black = button 'B').</p> <p>1.2b If checking voltage, a ground signal is present when button is pressed and float when not pressed.</p> <p>1.2c If checking ohms, the outputs should read 9-ohms when button is pressed and 0- ohms when not pressed.</p> <p>1.2d If outputs read nothing when pressed or not pressed, then the power supply is damaged.</p> <p>1.2e Send back to factory for repair or replacement.</p> <p>1.2f <i>Any of the above problems can be caused by a defective unit or damage by the customer from over-voltage, over-current or testing the inputs and outputs using a test light instead of a voltmeter.</i></p> <p>1.3 Check wire and equipment for problem</p>
Symptom	Possible Cause	Corrective Action
<p>2.0 Signal transmitted and received, but no operation.</p>	<p>2.1 No signal from transmitter</p> <p>2.2 One or both of the outputs have failed</p> <p>2.3 Receiver has failed outputs</p>	<p>2.1 Check wire harness for loose connections or damaged wires or terminals</p> <p>2.2 Check equipment for problem in motors or relays</p> <p>2.3 Recheck section 1.0</p>

Trouble Shooting Guide - 814 Series Remote Control



**Use a digital or analog voltmeter to check power and voltage!
Do NOT use a test light**

Symptom	Possible Cause	Corrective Action
3.0 No power to remote control receiver	3.1 Logic ground or power connection to receiver has failed 3.2 Chassis ground connection has failed	3.1a Check logic ground (black wire) and logic power (red wire). Use a voltmeter probe when checking voltage. 3.1b If either ground or power is not present, then locate failure in wire harness and repair. 3.2a Check chassis ground connection, it should be clean and tight, no paint on metal, an external tooth star washer should be present, no rust or dirt in connection. 3.2b Chassis ground should be located on vehicle frame.
Symptom	Possible Cause	Corrective Action
4.0 No signal (code) being transmitted	4.1 Battery voltage low 4.2 Transmitter is not sending a signal 4.3 Transmitter code is incorrect 4.4 Not all buttons send a signal when pressed.	4.1 Check battery voltage. Replace battery if voltage is 11.5 volts or less. (Signal strength is dependent upon battery voltage.) 4.2 Place probe from voltmeter on battery (+) and (-) leads. Press any button, voltage should change by 0.2 to 0.3 volts if a signal is transmitted. Check both buttons. 4.3a If transmitter is sending a signal and no signal is being received, re-code transmitter. 4.3b Send back to factory for re-coding. 4.4 If a signal is not transmitted on all buttons, send back to factory for repair or replacement.
Symptom	Possible Cause	Corrective Action
5.0 Poor range 0' to 25' (pulsating 0' to 25')	5.1 Antenna damaged or grounded	5.1a Check antenna placement, it should not be touching any metal or tinted glass. 5.1b It should not be closer than 6' to any motors or relays. 5.1c If it is coiled, then stretch it out and place near a window. 5.1d If antenna is cut or damaged, send back to factory for repair. 5.1e <i>NOTE: Antenna can NOT be shortened or altered in any way</i>

Trouble Shooting Guide - 814 Series Remote Control

Symptom	Possible Cause	Corrective Action
5.0 Poor range 0' to 25' (pulsating 0' to 25')	5.2 Receiver installed in poor locations such as near door or lift motor	5.2a Disconnect door and / or ramp motor and recheck range. 5.2b If range is ok, then 'electrical noise' from motors is causing interference with RF signal. 5.2c Move receiver and antenna a minimum of 6 feet from the motors. 5.2d If moving receiver 6 feet does not improve, an external antenna may be required to boost signal.
	5.3 Receiver logic power input is exposed to radiated noise from wire harness or motors	5.3a Disconnect receiver logic power input from main wire harness 5.3b Run new wire from vehicle battery to red wire.
	5.4 Receiver logic ground is exposed to radiated noise from wire harness or motors	5.4a Disconnect receiver logic ground input from main wire harness 5.4b Remove black wire on receiver from wire harness and install on the vehicle frame for a new chassis ground or vehicle battery. 5.4c Remove any paint or residue from metal, use an external tooth star washer and tighten new chassis ground terminal securely to vehicle frame.
	5.5 Transmitter 9-volt battery is low	5.5 Replace battery if voltage is 11.5 volts or below
	5.6 Out of 25 foot range	5.6 Move closer to the vehicle
	5.7 Interference	5.7a Electromagnetic interference (EMI) caused by any radio frequency (RF) nearby, motors, welding equipment, relays, etc. May be in close proximity to receiver / transmitter. 5.7b Move closer to antenna or move vehicle out of range of EMI caused by radio frequency, welding equipment, as this is a temporary problem. 5.7c If EMI is caused by relays, door motors or lift motors then the receiver must be moved or shielded or the EMI noise diverted to ground. Call the factory for details.
	5.8 Component of receiver damaged or defective	5.8 Send back to factory for repair or replacement.
	5.9 Other equipment installed in vehicle causing voltage drop when initially turning on	5.9 Remove all other equipment from logic ground and power.

TouchTronics, Inc. Warranty Policies and Procedures

The following revised warranty procedures will be implemented and effective March 1, 2002.

- 1) All products will now be shipped with an individual bar code attached.
- 2) The bar code will include some or all of the following information.
 - A) Date of Manufacture
 - B) Serial Number
 - C) Private Code
 - D) Part Number
- 3) Warranty Cards are no longer required to be eligible to receive technical support and service.
- 4) Each individual product is warranted under the TouchTronics Limited Warranty program for 1 full year from date of purchase or a *maximum* of 2 years from the date of manufacture.
- 5) No product will be covered under the TouchTronics Limited Warranty program that has a manufacture date older than 2 years.
- 6) To receive technical support or warranty service, simply call our technical support center during regular business hours.
- 7) To enable our technical support staff to better serve you, please have the following information available when you call.

Date Of:	
Manufacture	
Purchase	
Installation	

Vehicle Information:	
Dealer Name	
Dealer Phone	
Make / Model	

Product Information:	
Part Number	
Serial Number	
Private Code	

Please fill in all pertinent information at the time of purchase or installation

Limited One (1) Year Warranty

Section One

Seller will warrant any product originally manufactured or assembled and sold by seller for a period of *up to TWO YEARS* (24 months) from the original date of manufacture or **ONE YEAR** (12 months) from the original retail sale or O.E.M. in-service date.

Section Two

The following are in lieu of all warranties; expressed; implied; or statutory, including but not limited to, any implied warranty of merchantability of fitness for a particular purpose and of any other warranty obligation on the part of seller. Seller, except as otherwise hereinafter provided, warrants the goods against faulty workmanship or the use of defective materials for a period of *up to TWO YEARS* (24 months) from the original date of manufacture or **ONE YEAR** (12 months) from the original retail or O.E.M. in-service date.

Sellers sole and exclusive liability shall be (at sellers option) to repair; replace; or credit buyer for such goods which are returned by buyer during the applicable warranty period set forth above, provided that (I) seller is promptly notified in writing or phone upon discovery by buyer that such goods failed to conform and an explanation of any alleged deficiencies, (II) such goods are returned to seller, (III) sellers examination of such goods shall disclose that such alleged deficiencies actually exist and were not caused by accident, misuse, neglect, alteration, improper installation, unauthorized repair or improper testing. If seller elects to repair or replace such goods, seller shall have a reasonable time to make such repairs or replace such goods.

Sellers warranties as herein above set forth shall not be enlarged, diminished, or affected by, and no obligation or liability shall arise or grow out of, sellers rendering of technical advice or service.

Damage to products caused by the customer or during installation cannot be claimed under this warranty. All devices returned that are not covered under the sellers warranty policy, will be charged a minimum of \$25.00 for evaluation plus additional charges for components and labor to repair the device not to exceed the original selling price. Seller considers the following to be typical examples of customer or installation damage: burned or broken traces on the printed circuit board, burned or damaged components, dirt or water residue on the printed circuit board or inside the case, modifications by the customer, broken cases or housings and dead batteries.

Section Three

A return material authorization number (RMA) must be issued by seller before any product is returned for evaluation or repair. Warranty repairs must be completed at authorized repair facilities.

Warrantypolicy1 rev a.doc
01.01.03 rev a
09.30.98 rev int
Effective January 1, 2003

This Page May Be Used For Installation Notes Or Diagrams: