

## XL 200 Street Thunder Light Bar Control Panel Operation Manual and Installation Guide

**Compact  
and  
Economical**



The XL 200 Street Thunder Light Bar Control Panel  
with push-button style switches.

### Special Features and Applications

#### **Momentary Switch**

Use this switch to open your gun lock or any similar device.

#### **Circuit Protection**

All of your switches are protected with on-board fuses.

#### **Backlighting**

Backlighting is standard on all switches and function lenses.

#### **Soft-Touch Switches**

Easy to use soft-touch push-button switches.

#### **Compact**

Easy to install any where, 6 1/2" x 2 1/2" x 2 1/2".

# Contents, Specifications, Installation Tools, Tech Support

## Contents

|   |             |
|---|-------------|
| Special Features and Applications                               | Page 1      |
| Contents, Specifications, Installation Tools, Technical Support | Page 2      |
| Component Parts List  | Page 3      |
| Operation: Light Bar Control Panel                              | Page 4      |
| Programming Details: Push Button Switches                       | Page 5      |
| Installation: Bracket and Panel                                 | Page 6      |
| Electrical Installation: Logic Power Inputs                     | Page 7      |
| Testing: Logic Power Circuit                                    | Page 8      |
| Electrical Installation: Switch Outputs                         | Page 9      |
| Testing: Final Checkout   | Page 10     |
| Trouble Shooting Guide  | Page 11, 12 |
| Limited One (1) Year Warranty                                   | Page 13     |

## Specifications

### Electrical:

|                     |   |
|---------------------|---|
| Switches 1, 2 & 3:  | 20 Amps each, Maximum combined current - 30 Amp fuse in panel |
| Switches 4, 5, & 6: | 20 Amps each, Maximum combined current - 30 Amp fuse in panel |

### Physical:

|          |   |
|----------|---|
| Panel:   | 6 ½" x 2 ½" x 2 ½" (width, height, depth) |
| Bracket: | 6" x 1 ½" (width, depth)                  |

### Illumination:

|                |          |
|----------------|----------|
| Switches 1-6:  | Status   |
| Lens Function: | Location |



## Installation Tools

|                              |  |
|------------------------------|--|
| Voltmeter, analog or digital |  |
| Phillips Screw Driver        |  |
| Adjustable Wrench            |  |
| #8 Hex Head Screw Driver     |  |
| #10 Hex Head Screw Driver    |  |
| Wire Cutter                  |  |
| Wire Stripper                |  |
| To Clean Grounding Pad:      | Scraper, Sand Paper, Alcohol Based Cleaner |

## Technical Support

Visit the factory website to download a copy of these instructions, e-mail technical questions and see other TouchTronics, Inc. Products.

### Phone Numbers

Gall's, Inc: 1-800-477-7766  
 TouchTronics, Inc. 1-800-294-2570 or 1-574-294-2570

### Web Site

[www.touchtronics.com](http://www.touchtronics.com)

### E-Mail

[Touchtronics@touchtronics.com](mailto:Touchtronics@touchtronics.com) or  
[Techsupport@touchtronics.com](mailto:Techsupport@touchtronics.com) or  
 'Contact Request' link on the web page

# Component Parts List

1) 1 pc **M606** Switch Panel, 6 function



2) 1 set **C606.G1** XL 200 Switch Function Lens Strip



3) 1 pc **C606.J1** Mounting Bracket



4) 1 kit **C606.F1** Fastener kit (panel & bracket)

2pcs BLT.5000 Hex Head Bolt 1/4-28 3/4"



2pcs NTS.6005 Nylock Nut 1/4-28



6pcs SCW.7001 Hex Head Screw 8 x 1/2"



2pcs SCW.7002 Hex Head Screw 10 x 3/4"



1pcs TRM.8001 Terminal #10 ring 3/16"



1pcs WSH.9000 Washer, Ext Tooth #10 3/16"



5) 1 kit **C606.H1** XL 200 Panel Harness Kit

(All 14 gauge, single wires with fully insulated .250 female terminal)

- 1pc SL 1 Pink
- 1pc SL 2 Red
- 1pc SL 3 Black
- 1pc SL 4 Orange
- 1pc SL 5 Violet
- 1pc SL 6 Gray
- 1pc SL 7 Brown
- 1pc SL 8 Light Blue
- 1pc SL 9 Dark Blue
- 1pc SL 10 Green
- 1pc SL 11 Orange

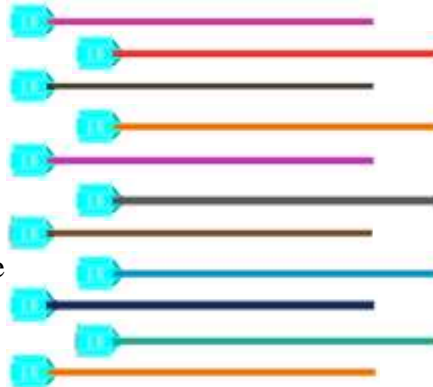

6) 1pc **TIE.T50MR** Cable tie, 7.5" - w/mount hole

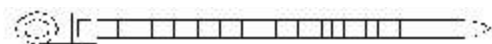

## Operation: Light Bar Control Panel



### Push Button Switches

- 1 Press switch button to toggle between: ON and OFF
- 2 Switch changes color to indicate status: None = OFF  
Red = ON
- 3 All function lenses are back lit when power (+12v) is supplied to panel.

### Plan Your Installation

To maximize this panels special capabilities, plan ahead. Determine the switch functions, lights and if the momentary switch program option will be used.

### Default Factory Push-Button Switch Settings

All push-button switches are factory set at 'Latching' / Toggle . . . . . Push On - Push Off

### Momentary Option - Switch 3

On only when button is pressed.

### WARNING!

Use **ONLY** a volt meter to check voltage during installation and testing

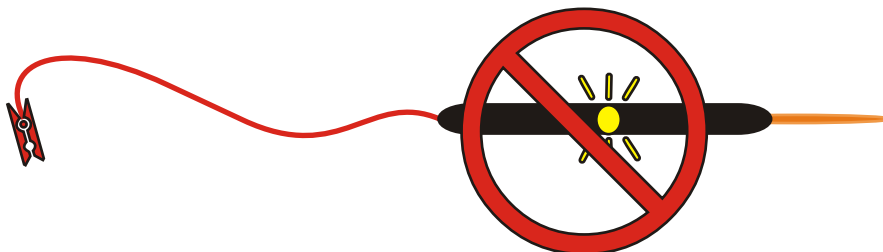

## Programming Details: Push-Button Switches

### Program Push-Button Switches

- 1) Locate the small hole in lower right-hand corner of panel front. Inside the small hole is the "Program Switch".
  - 2) Insert the end of a paper clip or similar device into the small hole, press and hold the Program Switch. Switch LEDs flash Off and then turn Off or flashes Red if a program is selected.
  - 3) When in program mode, no switch outputs will operate. The back lights flash when in program mode.
  - 4) Press Switch-3 one time. The switch will turn red, begin to flash and buzz to indicate the program is selected. To store the selected program, leave the switch in the program color, red and exit program mode.
  - 5) To exit program mode, insert the paper clip into the small hole, press and hold the Program Switch again until the switch LEDs flash off and then cycle and flash several times and finally turn Off. Switch outputs will operate.
  - 6) Retest Switch-3 to verify acceptance of program. If switch program is incorrect, reprogram switch a second time and retest program status.
- If problems persist call the factory at 1-800-294-2570.

*Switch 1, 2, 4, 5 and 6*

#### Factory Default

On - Off - Latching

*Switch 3*

#### Factory Default

On - Off - Latching

#### Momentary (Program Flashing Red)

Momentary On - Press and hold switch to select the momentary 'On' time. The output will stay 'On' for as long as the switch is pressed.

For example: If switch 3 is pressed and held for 3-seconds during programming, in normal operation the output will stay on for 3-seconds each time switch 3 is pressed.

### Push Button Switch Status in Programming Mode

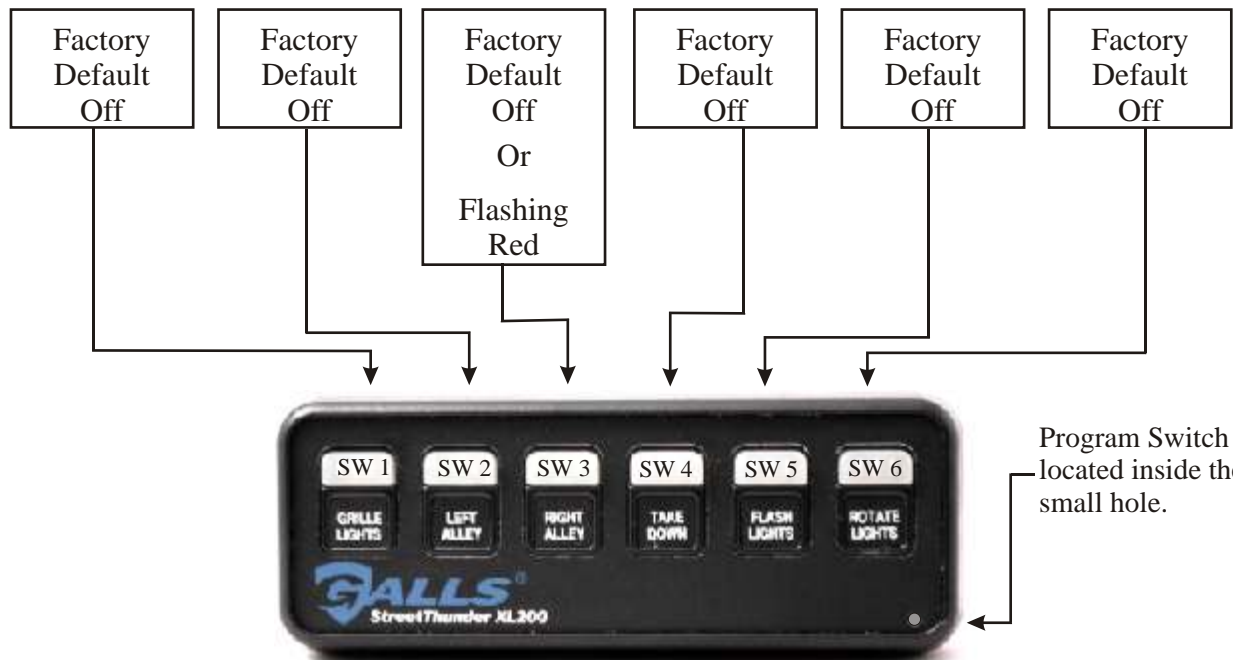

## Installation: Bracket and Panel

### Mount Bracket To Panel

- 1) Select 4pcs of the #8-1/2" hex head screws (SCW.7001) from the fastener kit (C606.F1).
- 2) Position mounting bracket (C606.J1) over the mounting holes in the panel (M606).
- 3) Using screw driver, screw the bracket to the panel.

### Mount Bracket and Panel to Console or Stack Unit

- 1) Select 2pcs of the 1/4-28 3/4" hex head bolts (BLT.5000) and 2pcs of the 1/4-28 nylock nuts (NTS.6005) from the fastener kit (C606.F1).
- 2) Position the panel bracket sides between rack on stack unit.
- 3) Insert a hex head bolt through rack slot and through bracket slot on each side.
- 4) Place nylock nuts on the hex head bolts and screw until finger tight.
- 5) Rotate the panel front for optimum positioning.
- 6) Tighten the nylock nuts to secure panel in proper position.

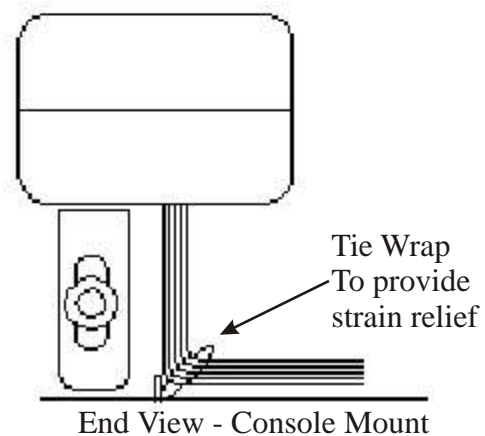
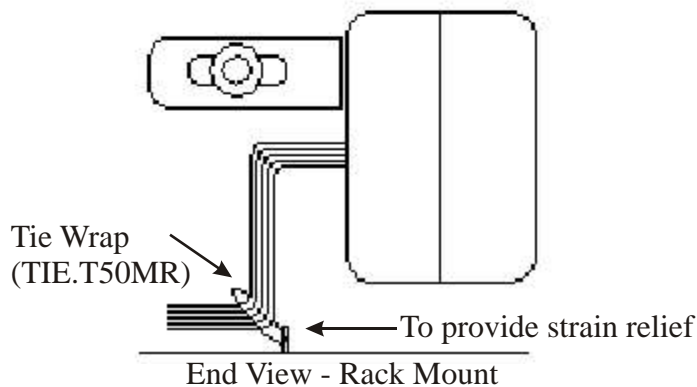
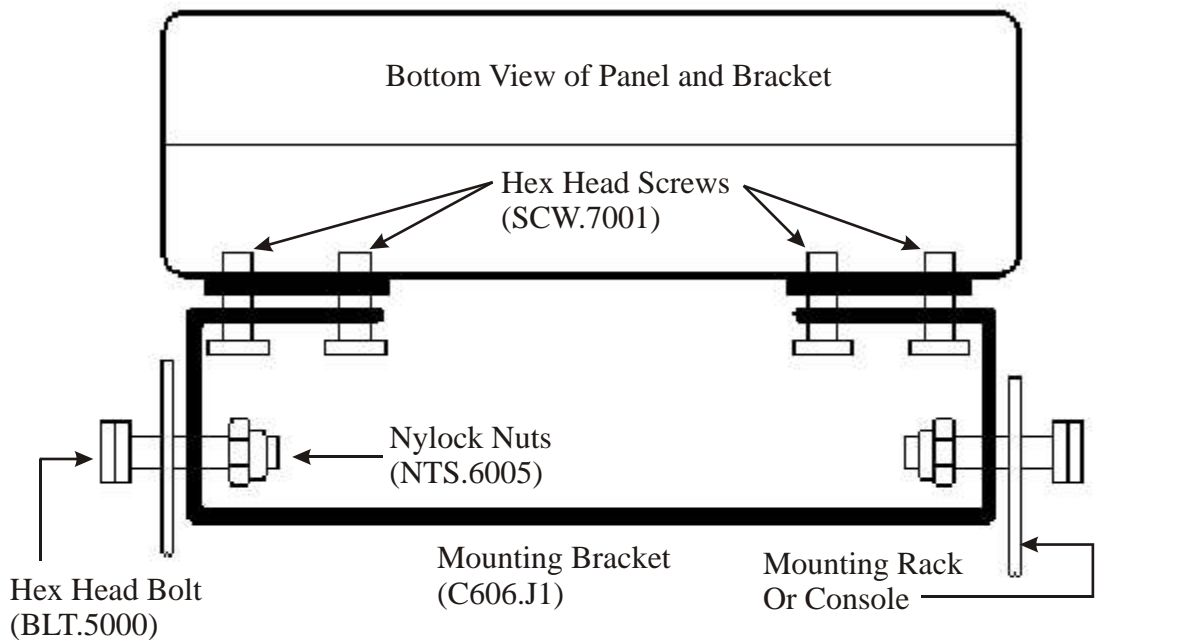

## Electrical Installation: Logic Power Inputs

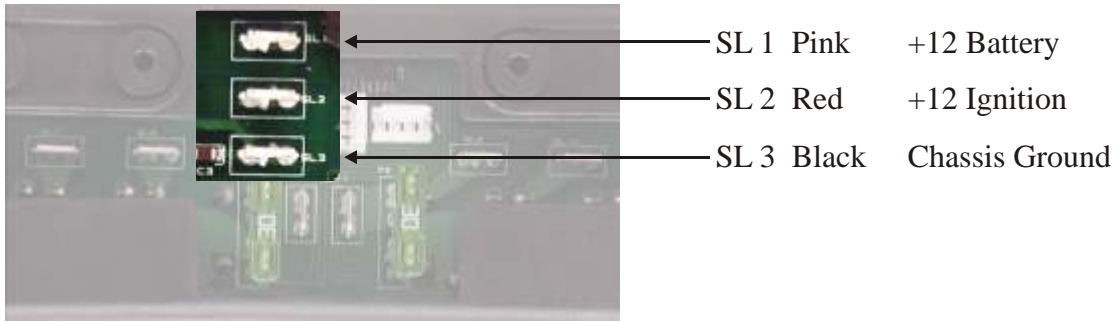

- SL 1 Pink +12 Battery
- SL 2 Red +12 Ignition
- SL 3 Black Chassis Ground

- 1) Connect the Pink wire, SL1, to a constant +12v battery power source.  
 Note: For best performance, run a clean +12v (100mA) directly from the battery or a fuse that is NOT supplying any power to the light bar or any other type of high current device.
- 2) Connect the Red wire, SL2, to +12v Ignition Power:  
 Install the Ignition input (100mA) by running a wire to an ignition fuse or circuit that is only HOT when the ignition switch is ON and in the RUN position.
- 3) Connect the Black wire, SL3, to Chassis Ground:
  - A) Scrape all paint and grease away from the body frame.
  - B) Clean the area using an alcohol based cleaner to remove paint chips and grease.
  - C) Crimp the supplied #10, 3/16" ring terminal (TRM.8001) onto the J1-3 black ground wire.
  - D) Insert the ring terminal and the supplied #10, 3/16" star washer (WSH.9000) over the supplied 10x3/4" hex head, self-tapping ground screw (SCW.7001).
  - E) Tighten ground screw securely into clean frame area.
  - F) **A loose chassis ground connection WILL cause intermittent operation of relay panel relay outputs.**

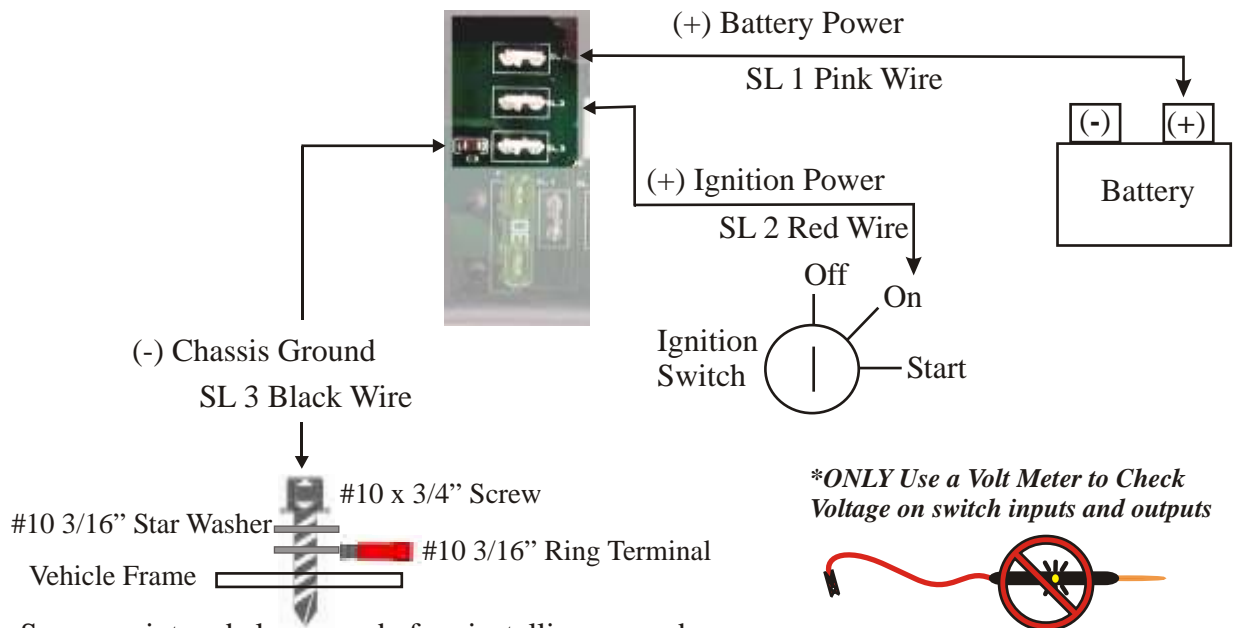

*\*ONLY Use a Volt Meter to Check Voltage on switch inputs and outputs*



Scrape paint and clean area before installing ground screw.  
**A loose chassis ground connection WILL cause intermittent operation of relay panel relay outputs**



## Testing: Power Circuit

**\*ONLY Use a Volt Meter to Check Voltage**



- 1) Set the volt meter to Volt Scale
  - A) Attach black lead from the volt meter to chassis ground.
  - B) Use the red meter lead to probe wires and verify meter readings against the chart below.  
The power input wires should NOT be plugged into the panel when doing this test.
- 2) Test voltage of each input before installing. After testing the Power Inputs, install them onto the panel back. Compare your meter readings with the chart below.

| Pin # | Wire Color | Correct Voltage Reading - Ignition Switch OFF | Correct Voltage Reading - Ignition Switch ON |
|-------|------------|---|--|
| SL 1  | Pink Wire  | +12v to 13.8v at ALL times                    | +12v to 13.8v at ALL times                   |
| SL 2  | Red Wire   | 0.0v to 1v                                    | +12v to 13.8v ONLY - In Run Position         |
| SL 3  | Black Wire | 0.0v to 0.5v at ALL times                     | 0.0v to 0.5v at ALL times                    |

- 2) Plug SL 1, SL 2 and SL 3 into panel. Ignition switch should be Off. Observe all switch and lens backlighting. All should be OFF.
- 3) Turn Ignition switch ON. Observe switch and lens.
  - A) Each switch will flash and cycle several times then turn Off.
  - B) All back light lens LEDs will turn On.
- 4) Press each switch in succession.
  - A) 1st press (ON), switch turns red and relay will click.
  - B) 2nd press (OFF) switch turns Off and relay will click.
- 5) If something fails, does not light or does not click correctly, review the instructions and check all connections for proper, solid crimps. If connections are solid, call the factory for technical assistance. Gall's Inc. technical assistance number is: 1-800-477-7766

## Electrical Installation: High Current Power

### Battery Power Source

- 1) Run two (2) 12 gauge wires (not supplied) from the battery to Light Bar Control Panel.
- 2) Install a 30 Amp Auto-Reset circuit breaker (not supplied) onto each wire within at least 18" of the battery.

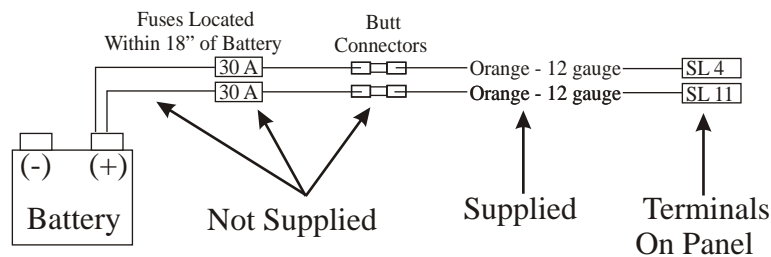

- Fuse 2 - Switches 1, 2 & 3
- SL 4 - Orange +12 Battery
- SL 11 - Orange +12 Battery
- Fuse 1 - Switches 4, 5 & 6



## Electrical Installation: Switch Outputs

**Before installing outputs test voltage**  
*\*ONLY Use a Volt Meter to Check Voltage on switch inputs and outputs*



### Pre-Testing the 30 Amp Inputs and Switch Outputs

- 1) Set the volt meter to Volt Scale
  - A) Attach black lead from the volt meter to chassis ground.
  - B) Use the red meter lead to probe terminals and verify meter readings with the chart below.
  - C) Verify meter readings against the chart below.

| Pin # | Wire Color  | 30 Amp Input Voltage<br>(At all times) | Switch Off   | Switch On       |
|-------|-------------|--|--------------|-----------------|
| SL 4  | Orange Wire | +12v to 13.8v                          |              |                 |
| SL 11 | Orange Wire | +12v to 13.8v                          |              |                 |
| SL 5  | Violet Wire |  | 0.0v to 1.0v | 12.0v to 13.8v  |
| SL 6  | Gray Wire   |  | 0.0v to 1.0v | 12.0v to 13.8v  |
| SL 7  | Brown Wire  |  | 0.0v to 1.0v | 12.0v to 13.8v  |
| SL 8  | Tan Wire    |  | 0.0v to 1.0v | 12.0v to 13.8v  |
| SL 9  | Blue Wire   |  | 0.0v to 1.0v | 12.0v to 13.8v  |
| SL 10 | Green Wire  |  | 0.0v to 1.0v | 12.0v to- 13.8v |

2) If a failure occurs or an improper voltage is found, review the instructions and check to ensure all connections are proper and solidly crimped. If connections are solid, call the factory for technical assistance. Gall's Inc. technical assistance number is: 1-800-477-7766

**Please Note: This photo has been rotated for ease of readability. The mounting holes are actually on the bottom of the panel.**

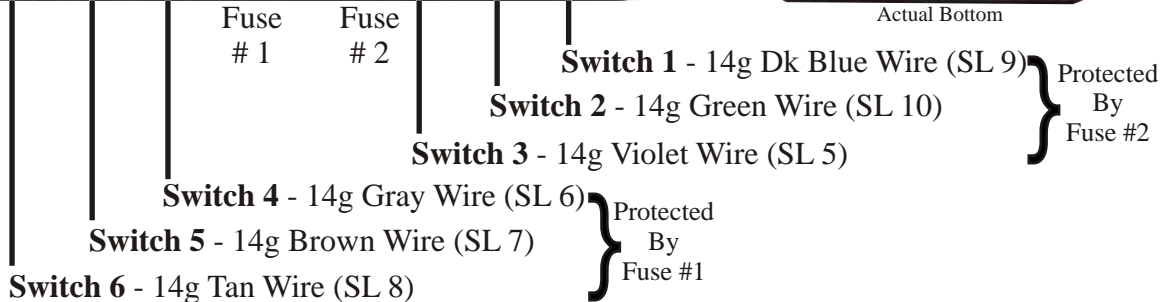
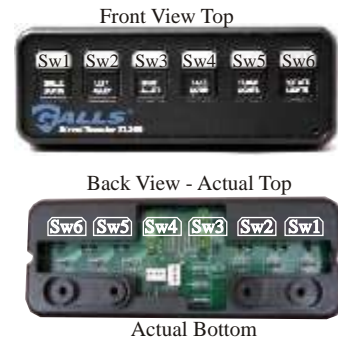
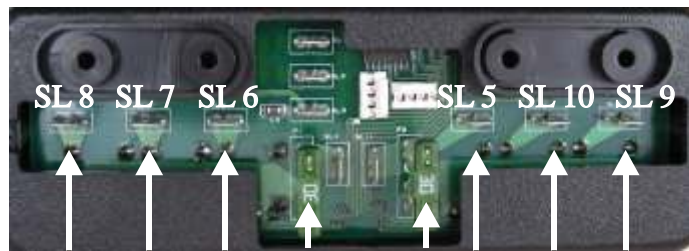

### Switch Output Installation

- 1) Determine if Switch 3 will be programmed.
- 2) Connect the lights to the wires per your plan.
- 3) Program push-button switch, if required. See page 5 for program details and instructions.

## Testing: Final Check-Out

- 1) Test outputs
  - A) One at a time, turn all push-button switch outputs On.
  - B) The proper light should turn ON. If it is a momentary - verify that function is On only when you are pressing the switch or that it turns Off automatically if the switch has been programmed for more than 1-second.
  - C) If any light does not turn on properly - check all connections and voltages (See table on page 9) before calling for technical assistance.
  
- 2) Remove each fuse one at a time and check to see which switches do not operate.

|        |                     |
|--------|---------------------|
| Fuse 1 | Switches 4, 5 and 6 |
| Fuse 2 | Switches 1, 2 and 3 |

## Trouble Shooting Guide

**Use a digital or analog voltmeter to check power and voltage!**

| Symptom   | Possible Cause  | Remedy   |
|---|---|--|
| <p><b>1.0</b> Switches and lenses are not backlit and relays do not click when switch is pressed.</p> | <p><b>1.1</b> No power (+12v) or ground on logic power inputs.</p> <p><b>1.2</b> Terminals are loose.</p> <p><b>1.3</b> Microprocessor, which controls panel logic, is not active.</p> <p><b>1.4</b> Wire installed on wrong terminals.</p> | <p><b>1.1a</b> Check +12 voltage on Pink wire (SL 1). Should be +12v at all times.</p> <p><b>1.1b</b> Check +12 voltage on Red wire (SL 2). Should be +12v when ign is ON.</p> <p><b>1.1c</b> Check ground on Black wire ( SL 3).</p> <p><b>1.1d</b> Correct improperly crimped terminals.</p> <p><b>1.2</b> Remove terminals and reinstall. Push the terminals securely onto the panel.</p> <p><b>1.3</b> Return panel to factory for replacement</p> <p><b>1.4</b> Check wire installation and re-install if needed.</p> |
| <p><b>2.0</b> Panel will not maintain program</p>   | <p><b>2.1</b> Power (+12v) lost on battery logic wire.</p> <p><b>2.2</b> Battery logic Pink wire is not installed on correct terminal.</p> <p><b>2.3</b> Ground Connection is lost.</p>   | <p><b>2.1a</b> Check power (+12v) on Pink wire (SL 1). Power (+12v) should be present at all times, when ignition switch is ON or OFF.</p> <p><b>2.1b</b> Correct improperly crimped terminals.</p> <p><b>2.2</b> Correct installation pin-out of pink wire.</p> <p><b>2.3</b> Correct ground installation.</p>  |
| <p><b>3.0</b> Fuse blows or light will not turn on completely.</p>                                    | <p><b>3.1</b> Maximum current load has been exceeded.</p> <p><b>3.2</b> Wire size/gauge is too small for current load and length of wire.</p>   | <p><b>3.1</b> Check current requirement of lights operated in circuit. If too high separate lights or add extra relay with fuse.</p> <p><b>3.2</b> Increase wire size/gauge between panel and function or power source (battery).</p>  |

## Trouble Shooting Guide

| Symptom  | Possible Cause   | Remedy   |
|--|--|--|
| <p><b>4.0</b> Relays click, but the function/light does not turn ON.</p> | <p><b>4.1</b> No power (+12v) on one or all of the high current power input wires.</p> <p><b>4.2</b> Panel or master fuses blown.</p> <p><b>4.3</b> Improper ground on function, such as a light bar.</p> <p><b>4.4</b> Improper terminal crimp on wire harness.</p> <p><b>4.5</b> Function or light bar is defective.</p> | <p><b>4.1</b> Check power (+12v) on the Orange wires, SL 4 and SL 11. Locate where voltage is lost in harness and correct.</p> <p><b>4.2a*</b> Panel Fuses - Check voltage on both sides of each fuse. Replace if needed.</p> <p><b>4.2b*</b> Master Fuse - Check master fuse or circuit breaker, usually located within 18" of vehicle battery. Replace if needed.</p> <p><b>4.3a</b> Use volt meter to verify +12v on output terminal and on function that is not operating.</p> <p><b>4.3b</b> If +12v is present, check and correct any improper ground connections.</p> <p><b>4.4a</b> Use volt meter to verify +12v on output terminal and on function that is not operating.</p> <p><b>4.4b</b> Check voltage at all terminal crimps and connectors. Re-crimp or replace terminals if needed.</p> <p><b>4.5</b> If +12v is present, function light bar may be defective. Test function or light bar and replace if necessary.</p> |

\*Fuses are located on back of panel. Fuse #1 protects switch outputs 1, 2 and 3. Fuse #2 protects switch outputs 4, 5 and 6.

## TouchTronics, Inc. Warranty Policies and Procedures

The following revised warranty procedures will be implemented and effective March 1, 2002.

- 1) All products will now be shipped with an individual bar code attached.
- 2) The bar code will include some or all of the following information.
  - A) Date of Manufacture
  - B) Serial Number
  - C) Private Code
  - D) Part Number
- 3) Warranty Cards are no longer required to be eligible to receive technical support and service.
- 4) Each individual product is warranted under the TouchTronics Limited Warranty program for 1 full year from date of purchase or a *maximum* of 2 years from the date of manufacture.
- 5) No product will be covered under the TouchTronics Limited Warranty program that has a manufacture date older than 2 years.
- 6) To receive technical support or warranty service, simply call our technical support center during regular business hours.
- 7) To enable our technical support staff to better serve you, please have the following information available when you call.

| Date Of:     |  |
|--------------|--|
| Manufacture  |  |
| Purchase     |  |
| Installation |  |

| Vehicle Information: |  |
|----------------------|--|
| Dealer Name          |  |
| Dealer Phone         |  |
| Make / Model         |  |

| Product Information: |  |
|----------------------|--|
| Part Number          |  |
| Serial Number        |  |
| Private Code         |  |

**Please fill in all pertinent information at the time of purchase or installation**

### Limited One (1) Year Warranty

#### Section One

Seller will warranty any product originally manufactured and sold by seller for a period of 12 months (1 year) from the original retail sale or in-service date. It is the purchaser's responsibility to complete the warranty registration card and mail it to seller within thirty (30) days of the retail sale date. Seller will not warrant any product that does not have a warranty card on file with the seller's warranty department. Warranty card must be received within one year of the date of manufacture.

#### Section Two

The following are in lieu of all warranties, express, implied or statutory including but not limited to, any implied warranty of merchantability of fitness for a particular purpose and of any other warranty obligation on the part of seller. Sellers, except as otherwise hereinafter provided, warrant the goods against faulty workmanship or the use of defective materials for a period of one year.

Seller's sole and exclusive liability shall be (at seller's option) to repair, replace or credit buyer for and such goods which are returned by buyer during the applicable warranty period set forth above, provided that (I) seller is promptly notified in writing or phone upon discovery by buyer that such goods failed to conform and an explanation of any alleged deficiencies, (II) such goods are returned to seller, (III) seller's examination of such goods shall disclose that such alleged deficiencies actually exist and were not caused by accident, misuse, neglect, alteration, improper installation, unauthorized repair or improper testing. If seller elects to repair or replace such goods, seller shall have a reasonable time to make such repairs or replace such goods.

Seller's warranties as herein above set forth shall not be enlarged, diminished, or affected by, and no obligation or liability shall arise or grow out of, seller's rendering of technical advice or service.

Products damaged by the customer or during installation can not be claimed as a warranty. All devices returned that are not covered under the seller's warranty policy, will be charged a minimum of \$25.00 for evaluation plus additional charges for components and labor to repair the device not to exceed the original selling price. Seller considers the following to be typical examples of customer or installation damage: burned or broken traces on the printed circuit board, burned or damaged components, dirt or water residue on the printed circuit board or inside the case, modifications by the customer, broken cases or housings and dead batteries.

#### Section Three

A return material authorization number (RMA) must be issued by seller before any product is returned for evaluation or repair. Warranty repairs must be completed at authorized repair facilities.

**This Page May Be Used For Installation Notes Or Diagrams:**