

GALLS[®]

K9 Protector

Temperature Monitor For Use In Vehicles



Please read entire instruction manual *prior* to starting the K9 Protector - Temperature Monitoring System Installation.

Special Features and Applications

Selectable Temperature Alarm Triggers

Select the temperature at which the module will trigger, 87°F or 93°F ($\pm 2^\circ\text{F}$)

Automatic Action Outputs to Protect Your K9 Partner

- ❖ Fan On
- ❖ One or Two Window Drop
- ❖ Horn Alert
- ❖ Pager Alert

System Status Indicator Lights

- ❖ Alarm Trigger Temperature Selected Status
- ❖ Power Status
- ❖ Alarm Status

Diagnostics

K9 Protector module continuously monitors for temperature probe failure. Alarm triggers if temperature probe fails.

Automatic Off (CAUTION)

Key Off - K9 Protector Off

Contents, Installation Tools, Technical Support

Contents

| | |
|---|---------------|
| Special Features and Applications | Page 1 |
| Contents, Installation Tools, Technical Support | Page 2 |
| Specifications, Component Parts List | Page 3 |
| Operation: K9 Protector | Page 4, 5 |
| Installation: Electrical | Page 6 |
| Installation: Ignition, Battery Power & Ground | Page 7 |
| Installation: Electrical Test & Applications | Page 8 |
| Installation: Application Schematics | Page 8, 9, 10 |
| Installation: Setting Window Drop Times | Page 11 |
| Installation: Mounting | Page 11 |
| Installation: Testing Outputs | Page 12 |
| Trouble Shooting Guide | Page 13, 14 |
| Limited One (1) Year Warranty | Page 15 |
| Blank Page (Installation Notes or Diagrams) | Page 16 |

Installation Tools

| | |
|------------------------------|--|
| Voltmeter, analog or digital | Hand Drill |
| Phillips Screw Driver | Assorted Drill Bits |
| Adjustable Wrench | Needle Nose Pliers |
| Screw Driver | Wire / Connector Crimping Tool |
| Diagonal Wire Cutter | Wire Stripper |
| To Clean Grounding Pad: | Scraper, Sand Paper, Alcohol Based Cleaner |

Technical Support

Visit the factory website to download a copy of these instructions, e-mail technical questions and see other TouchTronics, Inc. products.

TouchTronics, Inc. Phone / Fax Numbers

| | |
|---------------|----------------|
| Indiana Local | 1-574-294-2570 |
| Toll Free | 1-800-294-2570 |
| Fax | 1-574-293-1611 |

TouchTronics, Inc. Web Site

www.touchtronics.com

TouchTronics, Inc. E-Mail

| | |
|-------------------|--|
| Customer Service | touchtronics@touchtronics.com |
| Technical Support | techsupport@touchtronics.com |
| Or | 'Contact Request' link on the web page |

Galls, Inc. Phone / Fax Numbers

| | |
|--------------------------------------|----------------|
| Customer Service / USA | 1-800-477-7766 |
| Customer Service / Canada, PR, US-VI | 1-888-733-5391 |
| Customer Service / Other | 1-859-266-7227 |
| Fax / USA | 1-800-944-2557 |
| Fax / Other | 1-859-269-4360 |







Galls Inc. Web Site

www.galls.com

Galls, Inc. E-Mail

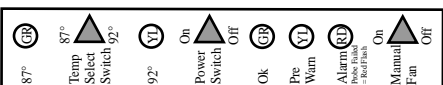
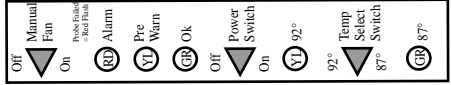
| | |
|-------------------|--|
| Customer Service | help-desk@galls.com |
| Technical Support | tech-support@galls.com |

Component Parts List

- | | | | | |
|----|-------|----------------|--|--|
| 1) | 1 pc | S852.L1 | K9 Protector Master Module |  |
| 2) | 1 pc | S852.T1 | Temperature Probe |  |
| 3) | 2 pcs | C852.H1 | 14 Way Wire Harness |  |
| 4) | 1 pc | C852.L2 | Right Hand - Side Mounted Status Indicator Label |  |
| | 1 pc | C852.L2 | Left Hand - Side Mounted Status Indicator Label |  |
| 5) | 2 pcs | SCW.7000 | 8 x 1/2" self drilling screw |  |
| 6) | 1 pc | SCW.7001 | 10 x 3/4" self drilling screw |  |
| 7) | 1 pc | WSH.9000 | 3/16" external tooth star washer |  |

Specifications

Specifications

| | |
|---------------------|-------------------------------------|
| Operating Voltage | 10 Volts DC to 18 Volts DC |
| Circuit Protection | |
| Logic Fuse | 0.75 Amp |
| Power Fuse | 20.0 Amp |
| Max Power Output | |
| Horn | 1 Amp |
| Window 1 | 5 Amps |
| Window 2 | 5 Amps |
| Fan | 7.5 Amps |
| Physical | |
| K9 Protector Module | 3" x 1" x 2" (width, height, depth) |
| Temperature Probe | 1 1/2" x 2" (width, length) |

Operation: K9 Protector

When the K9 Protector is turned On, it will not read the vehicle temperature for a period of 5 minutes, allowing time for the vehicle air conditioner to normalize the interior climate. At the end of the 5 minute period, the K9 Protector samples the interior temperature once every second and compares it to the alarm / trigger point that has been selected. The module sends a visible (yellow LED) and audible (double chirp) pre-warning anytime the interior temperature is within 1°F of selected alarm / trigger. The module sends a visual (red LED) and audible (2 short, 2 long, 2 short) warning anytime the interior temperature has reached the selected alarm / trigger point. Additionally, when the warning temperature has been reached, the module will drop the window and turn on a fan (if connected to the module). The warning alarm can only be deactivated by resetting the power switch on the K9 Protector module. The K9 Protector also performs a virtual 'hand-shake' with the external temperature probe every 3 seconds and will sound a warning anytime the probe does not respond.

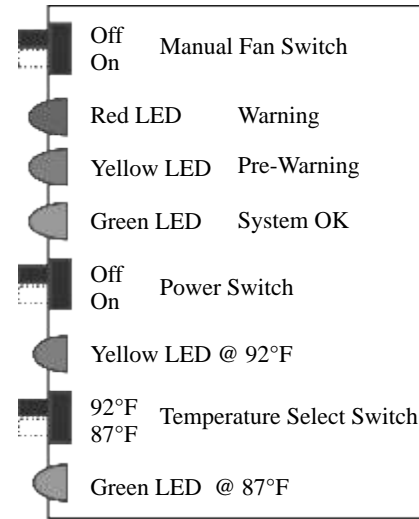

| Operation | Status Indicators | Window Drop (+) Output | Horn (-) Output | Fan* (+) Output | Pager (+) Output |
|-----------------------------------|-------------------------------|---|---|-----------------|------------------|
| Time Out @ Power Up 5 Minutes | Green LED - ON Flashing | Off | Off | Off | Off |
| Standard Operation | Green LED - ON Solid | Off | Off | Off | Off |
| Pre-Warning 1°F Temperature | Yellow LED - ON Solid | Off | One Double Chirp each time pre-warn reached | Off | None |
| Alarm / Trigger 87°F or 93°F ±2°F | Red LED - ON Solid | On-Set Timing | 2short/2 long/2 short @ 10 second intervals | On Continuous | On - 1 sec plse |
| Temperature Probe Failure | Red LED - ON Flashing | On | Double Chirp @ 3 second intervals | On | None |
| *Manual Fan | None | None | None | On | None |
| Temperature Selection | Temperature Select LED | *Manual fan operates at all times - not subject to K9 Protector power status. | | | |
| 87°F Trigger Temp ±2°F | Small Green on Solid | | | | |
| 93°F Trigger Temp ±2°F | Small Yellow on Solid | | | | |

Operation: K9 Protector

Time Out @ Power Up

When the ignition key is turned On, the alarm will NOT sound for 5 minutes while the vehicles interior climate normalizes. Occasionally the air inside a vehicle will take longer than 5 minutes to adjust. If the interior air temperature has not dropped below 87°F or 92°F $\pm 2^\circ\text{F}$ the alarm may trigger. If this happens, turn the K9 Protector power switch On / Off to reset the time-out function. During installation, the time-out can be bypassed by switching the power switch On / Off three times within a 5 second time period any time during the initial Power Up Time Out.

Automatic Window Drop

One or both windows can be set to drop automatically when the K9 Protector is triggered. The factory set drop-time is 2.5 seconds which will be correct for most vehicles. If the 2.5 second drop-time does not fit your vehicle, then it can be easily changed to a different drop-time. A dip switch is located inside the K9 Protector module to select other window drop-times.

Manual Fan

The fan may be turned On at any time using the slide switch located on the K9 Protector module. The fan will remain On when the alarm is triggered. *Please note: If the battery is disconnected and the fan switch is On, the fan will turn On when the battery is reconnected even though the K9 Protector module may be in the Off position.*

Alarm / Trigger Temperature Select Switch

The trigger temperature must be selected using the slide switch located on the K9 Protector module. It is factory set at 87°F. For hot, humid climates 87°F (small green LED) is usually the temperature trigger point selected. For hot, dry climates 92°F (small yellow LED) is usually the temperature trigger point selected. Temperatures in hot, humid climates have a higher heat index and are therefore more dangerous to the dog. ***It is important to note that what feels comfortable to a human may be reaching a dangerous point for the dog.***

Please Note: The K9 Protector temperature probe is calibrated to within $\pm 2^\circ\text{F}$ for the alarm / trigger point. The K9 Protector external temperature probe is specifically designed for this application. When compared to standard household thermometers, it will not correlate unless tested under standardized test conditions.

Horn Pattern

The horn patterns for the triggered alarm or failed external temperature probe are unique and recognizable. Check the operation table for horn pattern sequence on page 4.

Automatic Off

The K9 Protector module is designed to turn Off automatically each time the ignition is turned Off to prevent the alarm from triggering inadvertently or running down the battery. (This function may be bypassed if needed).

External Temperature Probe Failure

The K9 Protector module continually monitors the external temperature probe. Any time communication is lost between the external temperature probe and the master module, the alarm will trigger.

WARNING!

The K9 Protector Module is NOT designed to be used for children. DO NOT leave children unattended in a closed vehicle.

Installation: Electrical

To accommodate warranty installations with an old style wire harness, two (2) orange wires inputs are provided. On new installations, only one (1) orange wire needs to be connected as they are connected internally on the printed circuit board.

1) Install Logic Power

- A) Run 18g wire to a 'clean +12v' battery power source.
- B) Do NOT connect any power for motors or lights to this wire.
WARNING! The external temperature probe may be damaged by voltage spikes caused by lights or motors turning On at the same time it is taking a temperature reading.
- C) The circuit is protected by a 0.75 amp mini glass fuse located inside the K9 Protector module

2) Install Battery Power

- A) Run a 14g power wire to one or both of the orange wires J1-7 or J1-14. A smaller gauge wire may cause voltage drop between the battery and the K9 Protector module which can cause intermittent operation of the outputs.
- B) If running wire from battery, then install a fuse or circuit breaker (not supplied) within 18" of the battery.

3) Install Ground

Connect the Black wire to chassis ground

- A) Scrape all paint and grease away from the body frame.
A loose chassis ground connection WILL cause intermittent operation of receiver.
- B) Clean the area using an alcohol based cleaner to remove paint chips and grease.
- C) Crimp a #10, 3/16" ring terminal onto the black ground wire.
- D) Insert the ring terminal and a #10, 3/16" star washer over a 10x3/4" hex head, self-tapping ground screw.
- E) Tighten ground screw securely into clean frame area.

4) Install Ignition (+12vdc)

Install the yellow wire to the 'hot in run and accessory' wire on the vehicle ignition wire harness.

| Pin # | Wire Color | Input/Output | Amp Draw | Description |
|-------|------------|--------------|----------|---|
| 1 | Red | (+) Input | 0.75 amp | +12vdc Logic battery (fused @ 0.74amps) |
| 2 | Yellow | (+) Input | ---- | +12vdc Ignition Power |
| 3 | Black | (-) Input | ---- | (-) Chassis Ground |
| 4 | Violet | (-) Output | 5 amp | Horn - 5 amps maximum |
| 5 | Lt Green | (+) Output | 5 amp | Window Down #1 - Motor |
| 6 | ---- | ---- | ---- | ---- |
| 7 | Orange | (+) Input | 20 amp | Power +12vdc (fused @ 20 amps) |
| 8 | Tan | (+) Output | 10 amp | Fan - 7.5 amps maximum (see page -8-) |
| 9 | Dk Green | (-) Input | 5 amp | Window Down #1 - Switch input |
| 10 | Lt Blue | (+) Output | 5 amp | Window Down #2 - Motor |
| 11 | Pink | (+) Output | 1 amp | Pager - Not Supplied |
| 12 | Dk Blue | (-) Input | 5 amp | Window Down #2 - Switch input |
| 13 | ---- | ---- | ---- | ---- |
| 14 | Orange | (+) Input | 20 amp | Power +12vdc (fused @ 20 amps) |

Installation: Ignition, Battery Power & Ground

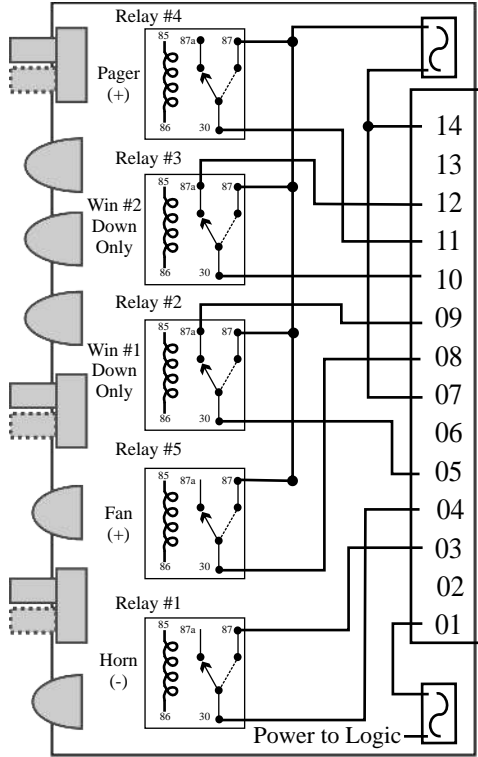

Mini ATO Style
Power Fuse - 20 Amps

| | | | |
|----|----------|------------------------|---|
| 14 | Orange | Power Input | See 1st paragraph on page -6- Optional for new installations |
| 13 | Empty | ---- | |
| 12 | Dk Blue | Window 2 - Motor Input | |
| 11 | Pink | Pager Output | |
| 10 | Lt Blue | Window 2 - Down Output | |
| 09 | Dk Green | Window 1 - Motor Input | |
| 08 | Tan | Fan Output | |
| 07 | Orange | Power Input | |
| 06 | Empty | ---- | |
| 05 | Lt Green | Window 1 - Down Output | |
| 04 | Violet | Horn Output | |
| 03 | Black | Chassis Ground | |
| 02 | Yellow | Key Switch | |
| 01 | Red | Logic Power | |

Mini Glass Style
Logic Fuse - 0.75 Amps

WARNING! If the +12v power feed on Orange wires (J1-14 and J1-7) are connected to the red logic wire (J1-1), the temperature probe may be damaged.

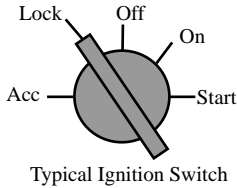

| | | |
|---------------|---|-----------------------------------|
| Battery Input | ← | Hot at all times from battery |
| Battery Input | ← | Hot at all times from battery |
| Start Output | → | Hot in start only to starter coil |
| On Output | → | Hot in run and start to ignition |
| Off | — | No connection |
| Lock | — | No connection |
| Acc Output | → | Hot in run and accessory |
| Acc Output | → | Hot in run only to heater |

| Ignition wire colors for 'hot in run & accessory' (some models may use different wire colors) | |
|--|----------------|
| Ford | Black / Pink |
| GM | Orange |
| Chrysler | Black / Orange |

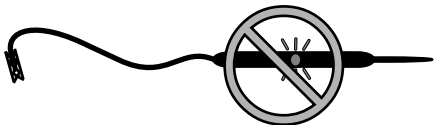

WARNING!
Use **ONLY** a volt meter to check voltage during installation and testing.
Using a test light **WILL** damage the outputs!

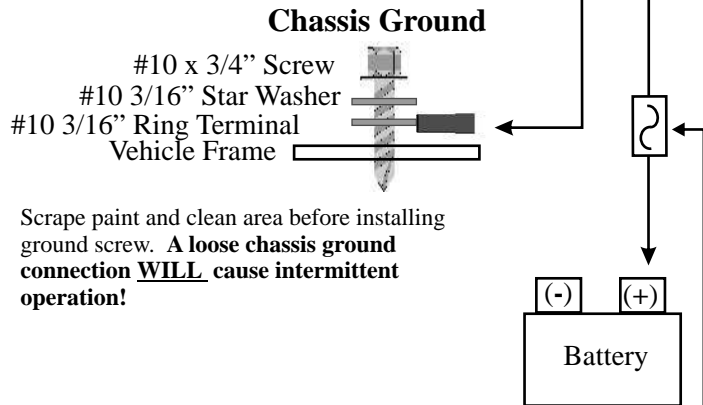

Scrape paint and clean area before installing ground screw. A loose chassis ground connection **WILL** cause intermittent operation!

Place 20 Amp auto reset circuit breaker or fuse (not supplied) within 18" of battery.

Installation: Electrical Test & Applications

1) Test Power & Ground Installation

- A) Vehicle ignition key in Off position
- B) Turn K9 Protector module power switch On
K9 Protector should NOT turn On
- C) Turn vehicle ignition key to On position
Large green LED should start flashing
One of the small LEDs (green/87°F or yellow/92°F) should be On solid

2) Test External Temperature Probe

- A) Rapidly turn the K9 Protector module power switch On/Off 3 to 4 times to bypass the time-out.
- B) Set the temperature select switch to 87°F (small green LED)
- C) Hold the temperature probe between fingers to raise the probe's temperature to above 87°F
When temperature reaches 86°F, the large yellow LED will turn On
When temperature reaches 87°F, the large red LED will turn On and relays will click
- D) Set the temperature select switch to 92°F (small yellow LED)
- E) Hold the temperature probe between fingers to raise the probe's temperature to above 92°F
When temperature reaches 91°F, the large yellow LED will turn On
When temperature reaches 92°F, the large red LED will turn On and relays will click

If the K9 Protector module operates correctly, continue with the installation.

If the K9 Protector module does NOT operate correctly, use a **volt meter** to verify proper voltage at all the power and ground inputs.

To test the voltage, clip the black test lead to chassis ground, turn the meter to 'volts dc'. Use the red test lead to probe the following inputs.

| Pin # | Pin Description | Correct Voltage |
|-------|----------------------|---|
| J1-1 | Logic Power Input | +12v - Battery Voltage |
| J1-2 | Ignition Power Input | +12v - Ignition Key On +0 v - Ignition Key Off |
| J1-3 | Ground Input | +0 v - Chassis ground |
| J1-7 | Power Input | +12v - Battery Voltage |
| J1-14 | Power Input | +12v - Battery Voltage |

Call factory if all voltages are correct and K9 Protector fails to turn On.

Installation: Application Schematics

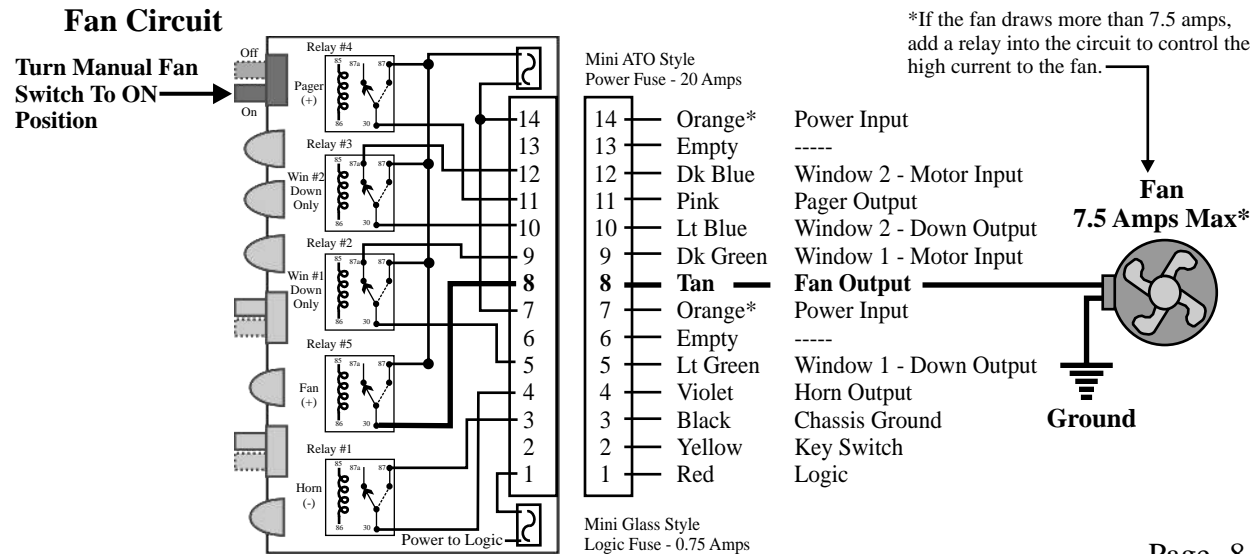

Installation: Application Schematics

Horn / Siren Circuit

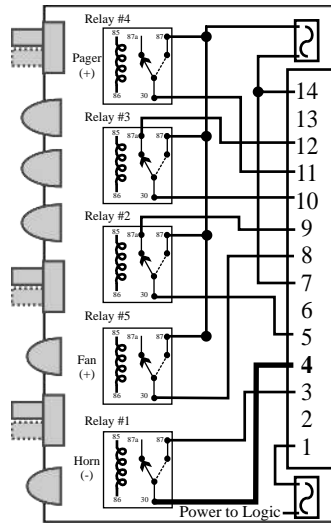

- Mini ATO Style
Power Fuse - 20 Amps
- | | | |
|----|---------------|----------------------------------|
| 14 | Orange* | Power Input |
| 13 | Empty | ---- |
| 12 | Dk Blue | Window 2 - Motor Input |
| 11 | Pink | Pager Output |
| 10 | Lt Blue | Window 2 - Down Output |
| 9 | Dk Green | Window 1 - Motor Input |
| 8 | Tan | Fan Output |
| 7 | Orange* | Power Input |
| 6 | Empty | ---- |
| 5 | Lt Green | Window 1 - Down Output |
| 4 | Violet | Horn Output (1 amp - GND) |
| 3 | Black | Chassis Ground |
| 2 | Yellow | Key Switch |
| 1 | Red | Logic |

Mini Glass Style
Logic Fuse - 0.75 Amps

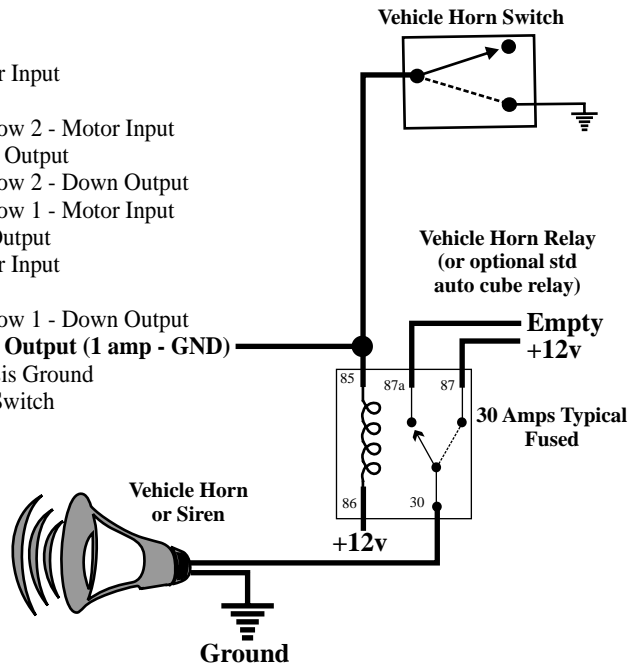

A siren can be installed instead of the vehicle horn. Most sirens are looking for a negative (ground) input. Check the amperage draw of the siren and if it is less than 1 amps, then you can change to the siren. If the siren draws more than 1 amp, put a 30 amp relay between the siren and the K9 Protector module output.

Optional Pager Circuit - Pager NOT Supplied In This Kit

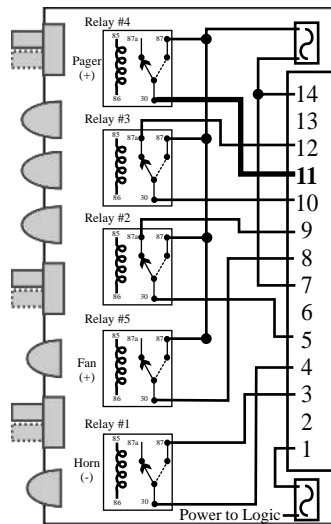

- Mini ATO Style
Power Fuse - 20 Amps
- | | | |
|----|-------------|------------------------|
| 14 | Orange* | Power Input |
| 13 | Empty | ---- |
| 12 | Dk Blue | Window 2 - Motor Input |
| 11 | Pink | Pager Output |
| 10 | Lt Blue | Window 2 - Down Output |
| 9 | Dk Green | Window 1 - Motor Input |
| 8 | Tan | Fan Output |
| 7 | Orange* | Power Input |
| 6 | Empty | ---- |
| 5 | Lt Green | Window 1 - Down Output |
| 4 | Violet | Horn Output |
| 3 | Black | Chassis Ground |
| 2 | Yellow | Key Switch |
| 1 | Red | Logic |

Mini Glass Style
Logic Fuse - 0.75 Amps

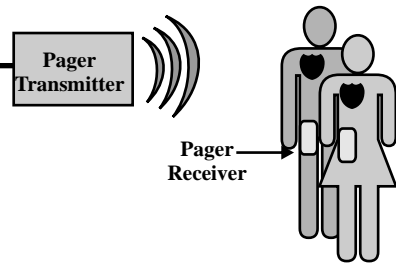

Installation: Application Schematics

Vehicle window switches and door lock switches can be designed as a positive pulse, a negative pulse or a reversal rest @ ground circuit.

To determine which type is used in your vehicle, take a voltmeter and probe one of the output wires at the switch. Check the polarity with the switch pressed and without the switch pressed. Compare results with the chart below.

| Window or Door Lock Switch | Switch NOT Pressed | Switch Pressed | Typical # of Wires |
|----------------------------|---------------------|----------------|--------------------|
| Positive Pulse | No Voltage / Floats | +12 Volts | 3 Wires |
| Negative Pulse | No Voltage / Floats | Ground | 3 Wires |
| Reversal Rest@Ground | Ground | +12 Volts | 5 Wires |

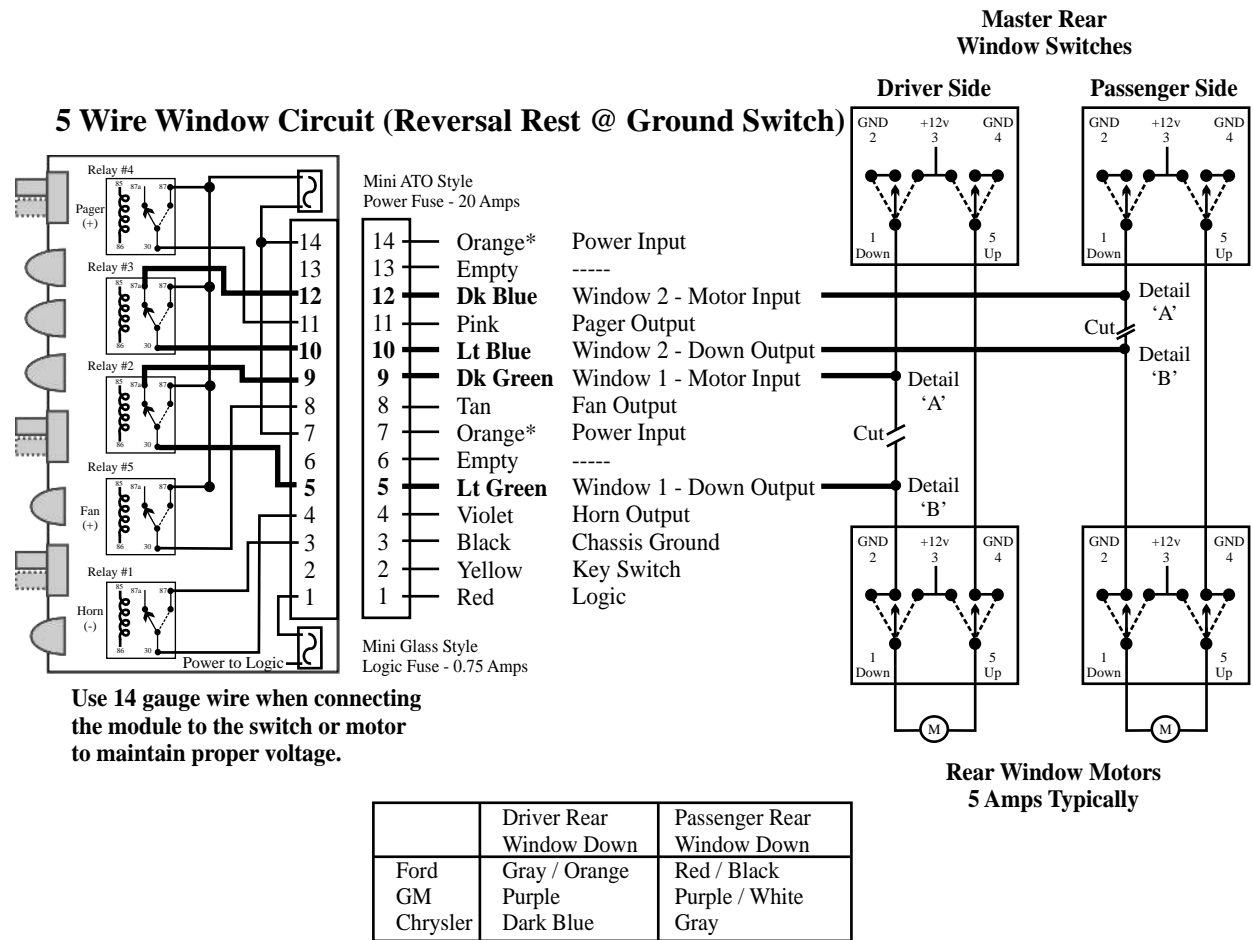

****Please Note:**

Due to continually changing wire colors through-out the automotive industry, TouchTronics can NOT provide accurate wire color information on a consistent basis. Therefore, if the wire colors needed for installation are not known, please contact a local dealer and they should be able to provide any necessary information.

Installation: Setting Window Drop Times

1) Set Window Drop Time

- A) Roll windows down several times and count the number of seconds it takes to move from a fully closed position to a fully open position.
- B) Check chart below to select the dip switch setting which matches the window drop time.
- C) Remove the cover from the K9 Protector module.
- D) Set dip switch 5 (see below) to the correct setting.

The factory setting is 2.5 second window drop time. This means that the window motor will turn On for a total of 2.5 seconds. **WARNING!** If the window reaches full open position in 1 second, the motor will stay in a Locked Rotor Condition for an additional 1.5 seconds. Most window motors can handle 1-2 seconds of Locked Rotor Condition and not blow a fuse or damage the K9 Protector module. However, if this condition occurs, the window fuse may not blow before the power trace on the K9 Protector module is damaged. This type of damage is not covered by warranty.

Windows should operate normally when window switch is pressed. Windows will drop for 2.5 seconds when alarm is triggered. The windows should move at a normal speed when triggered by the alarm. **The module does not automatically return the window to a closed position.**

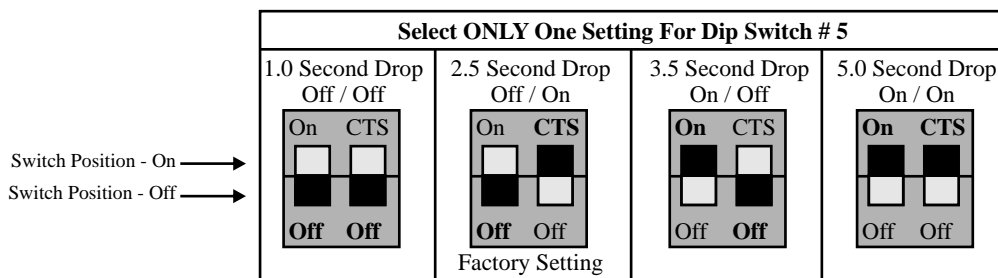

Installation: Mounting

K9 Protector Module Location

The K9 Protector module should be mounted in a location where you can easily see the status lights and reach the switches. Typically, it is mounted on the center console or on the K9 cage front, nearest to the driver. Do NOT mount the K9 Protector module where water or moisture can drop onto or seep into the K9 Protector module. The K9 Protector module is NOT moisture or water proof. Internal moisture and water damage can cause the K9 Protector module to function improperly or fail completely. This type of damage is NOT covered under warranty.

K9 Protector External Temperature Probe

The best place for the external temperature probe is about ten inches (10") above the floor. Attach it to the outside, center of the dog cage, near the front seats of the vehicle. A tie-wrap is supplied for securing the external temperature probe. Locating the probe between the top of the cage and the roof is NOT recommended because the air trapped there is typically hotter than the rest of the vehicle. Care should be taken to place the probe and the wiring in a location where the dog cannot reach.

Installation: Testing Outputs

1) Horn Test

- A) Press vehicle horn
Horn should sound when pressed, with normal tones
- B) Trigger K9 Protector module by setting temperature select switch to 87°F and hold probe between fingers to trigger module alarm
Horn should sound 'double chirp' at pre-warning temperature of 86°F
Horn should sound '2 short, 2 long, 2 short' at warning temperature of 87°F

2) Fan Test

- A) Turn manual fan switch On & Off
Fan should turn On & Off per switch selection
- B) Turn manual fan switch Off
- C) Trigger K9 Protector module by setting temperature select switch to 87°F and hold probe between fingers to trigger module alarm
Fan should turn On at warning temperature of 87°F

3) Pager Test (optional pager NOT supplied)

- A) Turn pager power switch to On
- B) Trigger K9 Protector module by setting temperature select switch to 87°F and hold probe between fingers to trigger module alarm
Alarm signal will be sent (+12v) to pager transmitter, which in turn, should activate the pager receiver. Timed output signal of 1 second @ 1 minute intervals.

4) Windows

- A) Roll each window down using master switch on the driver side
Both windows should roll down correctly
- B) Roll each window up using master switch
Both windows should roll up correctly

If a fuse blows, you probably have wired the K9 Protector backward or cut window wires in wrong place. Check installation schematics.

- C) Trigger K9 Protector module by setting temperature select switch to 87°F and hold probe between fingers to trigger module alarm
Both windows should roll down for the selected window drop time. If window rolls down and motor stays on for more than 1 additional second in a Lock Rotor Condition, open the module and select a shorter window drop time.

Trouble Shooting Guide - K9 Protector Module



**Use a digital or analog voltmeter to check power and voltage!
Do NOT use a test light!**

| Symptom | Possible Cause | Corrective Action |
|--|---|--|
| 1.0 No power to K9 Protector module | <p>1.1 Ground or power connection to module has failed.</p> <p>1.2 Chassis ground has failed.</p> | <p>1.1a Check ground (black wire) and logic power (red wire). Use a voltmeter when checking voltage.</p> <p>1.1b If either ground or power is not present, then locate failure in wire harness and repair.</p> <p>1.2a Check chassis ground connection, it should be clean and tight, no paint on metal, an external tooth star washer should be present, no rust or dirt in connection.</p> <p>1.2b Chassis ground should be located on vehicle frame.</p> |
| Symptom | Possible Cause | Corrective Action |
| 2.0 Fuse blows each time factory window switch is pressed | <p>2.1 Wire in factory window circuit was NOT cut.</p> <p>2.2 New wires in window circuit have been reversed.</p> | <p>2.1 Cut wire completely and then reconnect wires.</p> <p>2.2 Check K9 Protector in circuit. The input wire must be closest to the switch and the output wire must be closest to the window motor.</p> |
| Symptom | Possible Cause | Corrective Action |
| 3.0 K9 Protector does not trigger at 87°F or 92°F. | <p>3.1 Probe is mounted near an ac vent.</p> <p>3.2 External temperature probe calibration has failed.</p> | <p>3.1 Move probe to a location that is not subject to external heat and cooling sources.</p> <p>3.2 Test external temperature probe calibration</p> <p>a) Locate a standard thermometer, using a rubber band, attache the thermometer to the temperature probe (black rubber tip on the 10' gray cable).</p> <p>b) Close all windows and doors, turn on air conditioning to stabilize vehicle temperature to about 70°F.</p> <p>c) Turn on the K9 Protector module and by-pass the time-out feature.</p> <p>d) Large green LED should be On solid and alarm should NOT trigger.</p> <p>e) Turn heat on inside vehicle and slowly raise the temperature over a 5 minute time period to 87°F</p> <p>f) Alarm should trigger +/- 2°F of the 87°F trigger point.</p> <p>g) If there is a problem with temperature calibration and you are off by more than 3°F, please call the factory technical help line.</p> |
| <p><i>Note: Because the test in 3.2 can not be performed in a controlled environment, there will be some variance between the thermometer and the alarm trigger point.</i></p> | | |

Trouble Shooting Guide - K9 Protector Module



**Use a digital or analog voltmeter to check power and voltage!
Do NOT use a test light**

| Symptom | Possible Cause | Corrective Action |
|---|--|---|
| <p>4.0 Window moves slower when triggered by the K9 Protector module than it does when switch is pressed</p> | <p>4.1 Power wire from battery to K9 Protector module is too small for current draw causing a voltage drop.</p> | <p>4.1a Increase wire gauge size to 14awg or larger between the battery and the orange wires of the K9 Protector module wire harness.</p> |
| Symptom | Possible Cause | Corrective Action |
| <p>5.0 Window does not drop when alarm is triggered</p> | <p>5.1 Window drop is not installed correctly.</p> | <p>5.1 Test window voltage</p> <p>a) Check voltages at both driver and passenger window switch wires when switch is NOT pressed; it should be at ground potential. See detail 'A' on page 10</p> <p>b) Press switch, voltage should change to +12v and the window should move downward.</p> <p>c) Check voltages at both driver and passenger window switch wires when switch is NOT pressed; it should be at ground potential. See detail 'B' on page 10</p> <p>d) Press switch, voltage should change to +12v and the window should move downward.</p> <p>e) Check voltage on both orange wires. The potential should be +12v at all times.</p> <p>f) Set temperate select switch to 87°F</p> <p>g) Trigger alarm by holding probe between fingers, the voltage at check point 'B' should be at +12v while alarm is triggered.</p> <p>h) If all voltages are correct, then there is an improper connection to the window motor.</p> <p>i) If voltage at check point 'B' is NOT +12v and the orange wires are at +12v, call the factory technical help line.</p> |
| Symptom | Possible Cause | Corrective Action |
| <p>6.0 Large red LED flashes constantly</p> | <p>5.1 Probe has failed.</p> <p>5.2 Probe wire connector is loose.</p> | <p>5.1 Call factory for replacement</p> <p>5.2 Remove connector, clean and reinstall</p> |

TouchTronics, Inc. Warranty Policies and Procedures

The following revised warranty procedures will be implemented and effective March 1, 2002.

- 1) All products will now be shipped with an individual bar code attached.
- 2) The bar code will include some or all of the following information.
 - A) Date of Manufacture
 - B) Serial Number
 - C) Private Code
 - D) Part Number
- 3) Warranty Cards are no longer required to be eligible to receive technical support and service.
- 4) Each individual product is warranted under the TouchTronics Limited Warranty program for 1 full year from date of purchase or a *maximum* of 2 years from the date of manufacture.
- 5) No product will be covered under the TouchTronics Limited Warranty program that has a manufacture date older than 2 years.
- 6) To receive technical support or warranty service, simply call our technical support center during regular business hours.
- 7) To enable our technical support staff to better serve you, please have the following information available when you call.

| Date Of: | |
|--------------|--|
| Manufacture | |
| Purchase | |
| Installation | |

| Vehicle Information: | |
|----------------------|--|
| Dealer Name | |
| Dealer Phone | |
| Make / Model | |

| Product Information: | |
|----------------------|--|
| Part Number | |
| Serial Number | |
| Private Code | |

Please fill in all pertinent information at the time of purchase or installation

Limited One (1) Year Warranty

Section One

Seller will warranty any product originally manufactured and sold by seller for a period of 12 months (1 year) from the original retail sale or in-service date. It is the purchaser's responsibility to complete the warranty registration card and mail it to seller within thirty (30) days of the retail sale date. Seller will not warrant any product that does not have a warranty card on file with the seller's warranty department. Warranty card must be received within one year of the date of manufacture.

Section Two

The following are in lieu of all warranties, express, implied or statutory including but not limited to, any implied warranty of merchantability of fitness for a particular purpose and of any other warranty obligation on the part of seller. Sellers, except as otherwise hereinafter provided, warrant the goods against faulty workmanship or the use of defective materials for a period of one year.

Seller's sole and exclusive liability shall be (at seller's option) to repair, replace or credit buyer for and such goods which are returned by buyer during the applicable warranty period set forth above, provided that (I) seller is promptly notified in writing or phone upon discovery by buyer that such goods failed to conform and an explanation of any alleged deficiencies, (II) such goods are returned to seller, (III) seller's examination of such goods shall disclose that such alleged deficiencies actually exist and were not caused by accident, misuse, neglect, alteration, improper installation, unauthorized repair or improper testing. If seller elects to repair or replace such goods, seller shall have a reasonable time to make such repairs or replace such goods.

Seller's warranties as herein above set forth shall not be enlarged, diminished, or affected by, and no obligation or liability shall arise or grow out of, seller's rendering of technical advice or service.

Products damaged by the customer or during installation can not be claimed as a warranty. All devices returned that are not covered under the seller's warranty policy, will be charged a minimum of \$25.00 for evaluation plus additional charges for components and labor to repair the device not to exceed the original selling price. Seller considers the following to be typical examples of customer or installation damage: burned or broken traces on the printed circuit board, burned or damaged components, dirt or water residue on the printed circuit board or inside the case, modifications by the customer, broken cases or housings and dead batteries.

Section Three

A return material authorization number (RMA) must be issued by seller before any product is returned for evaluation or repair. Warranty repairs must be completed at authorized repair facilities.

This Page May Be Used For Installation Notes Or Diagrams: